

EXPERIMENT #7_1

EXAMINATION OF THE PARALLEL RL CIRCUIT FOR AC

REQUIRED MATERIALS:

1. Function generator
2. Oscilloscope (two channels)
3. AC Voltmeter
4. Y-0016/01AC module
5. Connection cable

EXPERIMENT:

Adjust the terminal of the function generator to sine, peak to peak value to **V_{pp}=10** Volt and frequency to **F=1 KHz**. Connect the **Y-0016/01AC** module to its place. Make the circuit connections as in the Figure. Apply the power to the circuit.

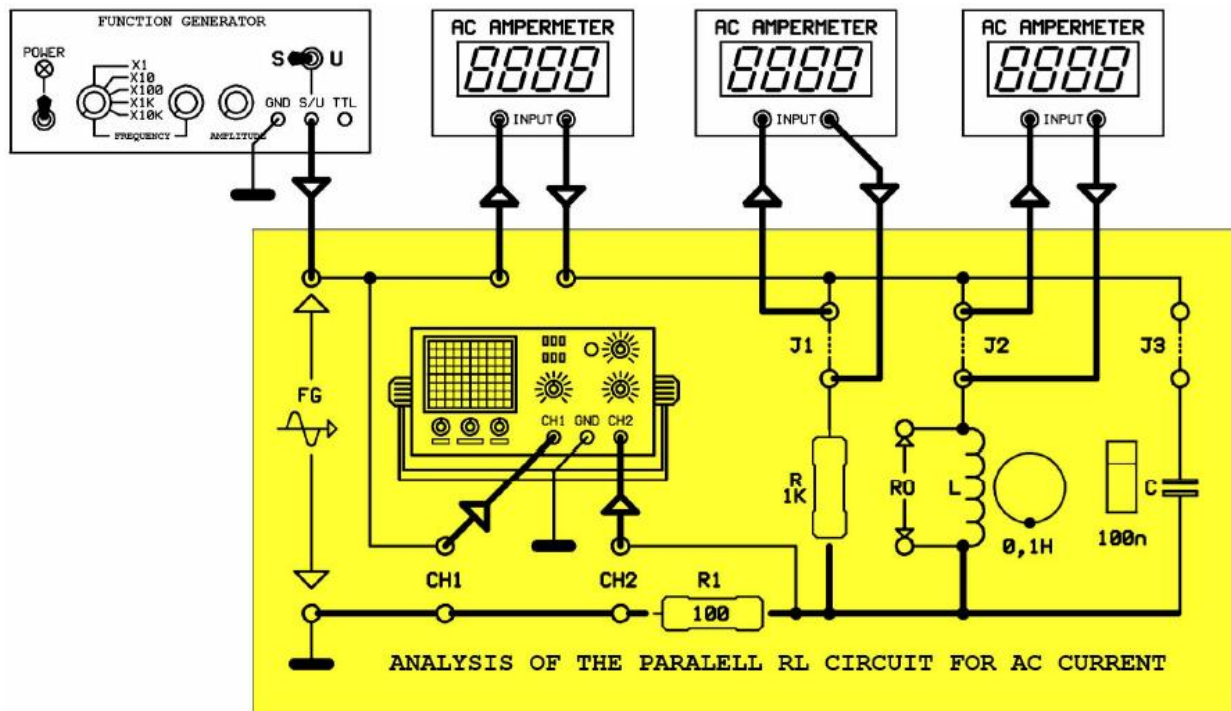

EXPERIMENT OBSERVATIONS

1. What can be said about the circuit looking at the waveform on the oscilloscope?

Short-circuit the CH2 points so that "R1" resistor will not effect the circuit.

2. Calculate the inductive reactance of the inductor.

3. Calculate the circuit current and currents passing through the legs of circuit.

4. Read the current values shown by Ampermeters. Compare the current values in Ampermeters with the calculated current values..

5. Draw the phasor diagram of the circuit.

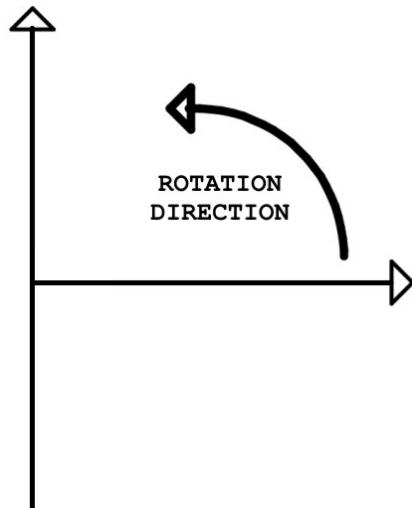

6. Find the circuit impedance using the values in measurement devices.

7. Find the power coefficient and phase angle of the circuit.

8. Calculate the active power dissipated using the values in measurement devices..