

ELECTRONICS LABORATORY

PART 1 EXPERIMENTS

Assoc. Prof. Serhan Yarkan

ISTANBUL COMMERCE UNIVERSITY

Contents

EXPERIMENT: 1.1 **2**
 EXAMINATION OF DIODES **2**
EXPERIMENT: 1.2 **3**
 DERIVING DIODE CHARACTERISTICS **3**
EXPERIMENT: 1.3 **6**
 EXAMINATION OF HALF WAVE RECTIFIER **6**
EXPERIMENT: 1.4 **8**
 EXAMINATION OF A FULL WAVE RECTIFIER **8**
EXPERIMENT: 1.5 **10**
 EXAMINATION OF BRIDGE TYPE FULL WAVE RECTIFIER **10**

EXPERIMENT: 1.1

EXAMINATION OF DIODES

Put Y-0016/005 module in place. Connect the circuit as shown in Figure 1.

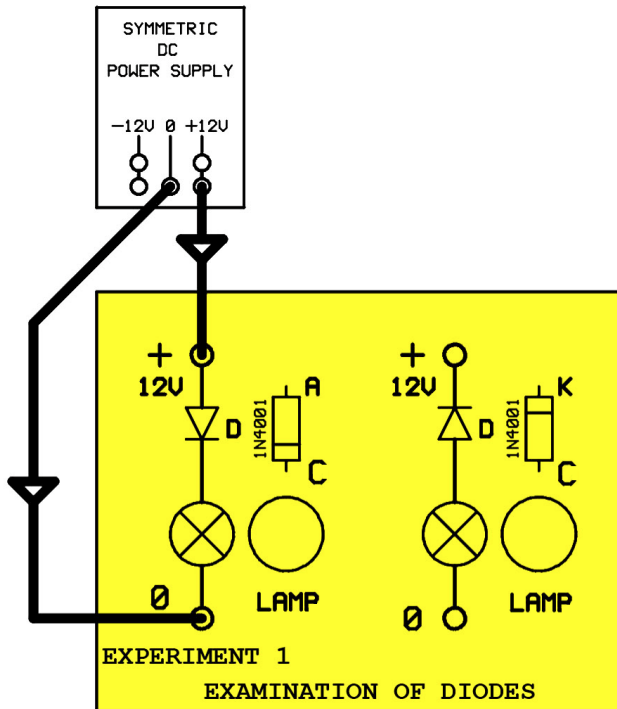

Figure 1

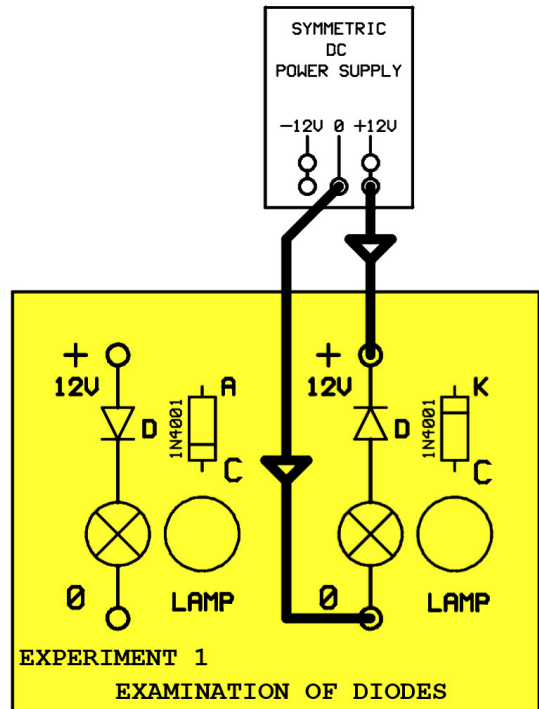

Figure 2

Apply the power to the circuit.

1- Is the lamp on? Why?

2- Close the circuit power. Connect the circuit as shown in Figure 2. Apply the power to the circuit. What is the result? Explain.

3- Based on Question1 and Question2, what should be Anode-Cathode voltages for diode being a conductor?

EXPERIMENT: 1.2 DERIVING DIODE CHARACTERISTICS

Put Y-0016/005 module in place. Connect the circuit as shown in Figure 3.

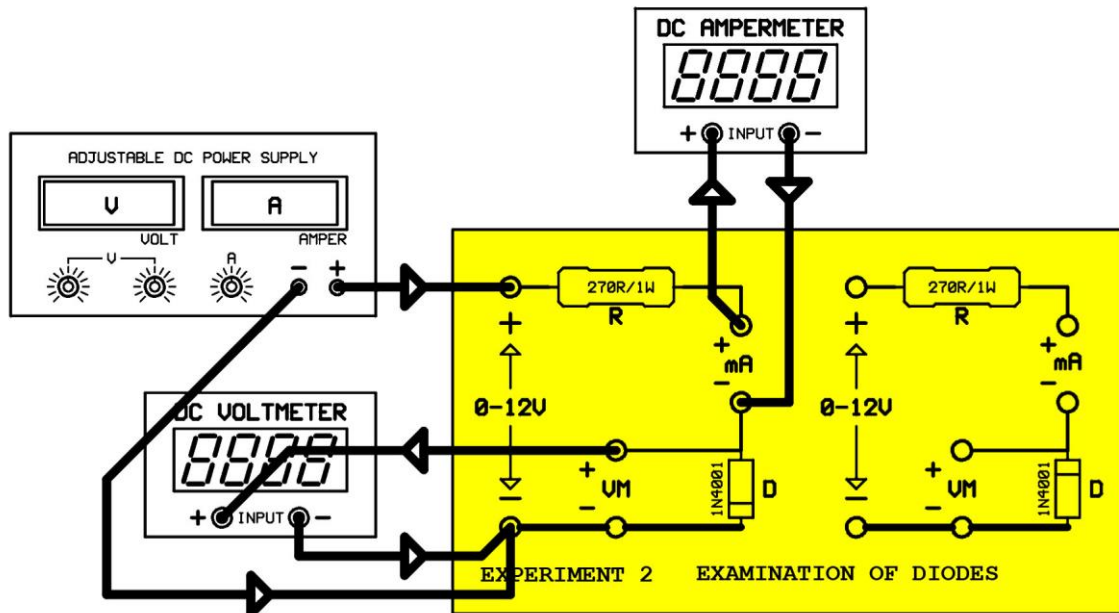

Figure 3

Adjust the power supply voltage potentiometer. to minimum (left), current potentiometer to maximum (right). Apply power to the circuit. In this arrangement, diode is in forward bias region.

1- By using the amperimeter, obtain the values shown in the table of Figure 4 step by step. Record the voltmeter voltage values for each of the current value to the table.

NUMBER	ID (mA)	ED (V)	RD
1	0		
2	0,02		
3	0,05		
4	0,1		
5	0,2		
6	0,5		
7	0,8		
8	1,0		
9	2,0		
10	5,0		
11	10,0		
12	12,0		

Figure 4

2- Evaluate the resistance of the diode at each step by using the relation $RD = \frac{ED}{ID}$, and record these values to the Figure 4 again.

3- Mark the values of ID versus ED in Figure 4 onto the graph shown in Figure 5 and obtain the forward bias curve of the diode.

Figure 5

4- Cut the power of the circuit. Connect the circuit as shown in Figure 6. In this arrangement, the diode is reversely biased.

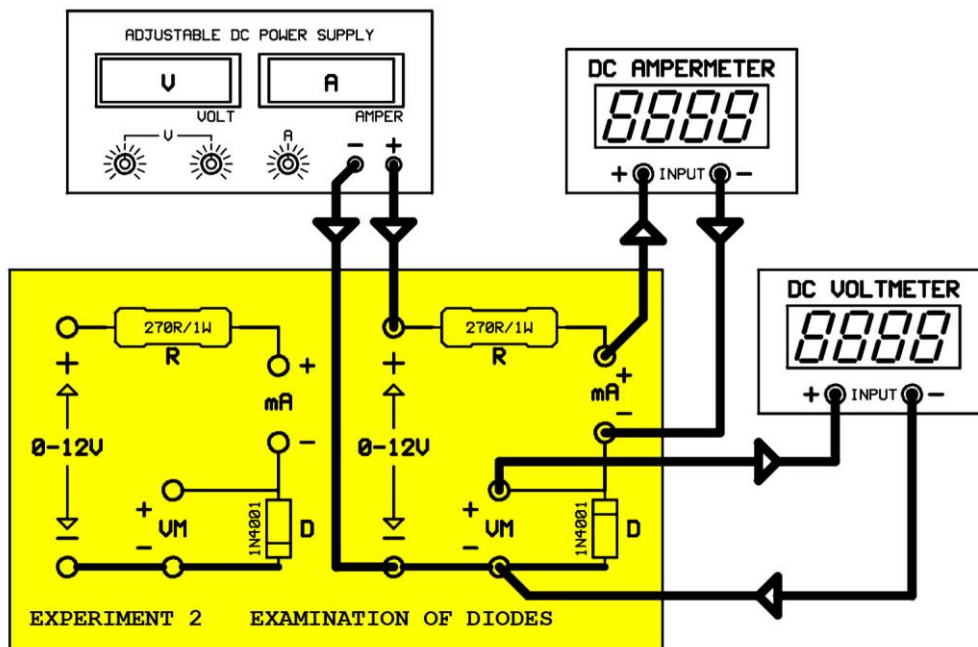

Figure 6

This time, by using the voltmeter, obtain the values of ED step by step by adjusting the power supply. Record the ampermeter current value for each of the voltage value to the table.

NUMBER	ED (V)	ID (μ A)
1	0	
2	4	
3	8	
4	12	

Figure 7

5- What is the meaning of current (in the order of μ A) passing when the diode is in reverse bias ?

6- Mark the values of ID versus ED in Figure 7 onto the graph shown in Figure 8 and obtain the forward bias curve of the diode.

Figure 8

7- What can be derived from the Figure 8?

EXPERIMENT: 1.3

EXAMINATION OF HALF WAVE RECTIFIER

Put Y-0016/005 module in place. Connect the circuit shown in Figure 9.

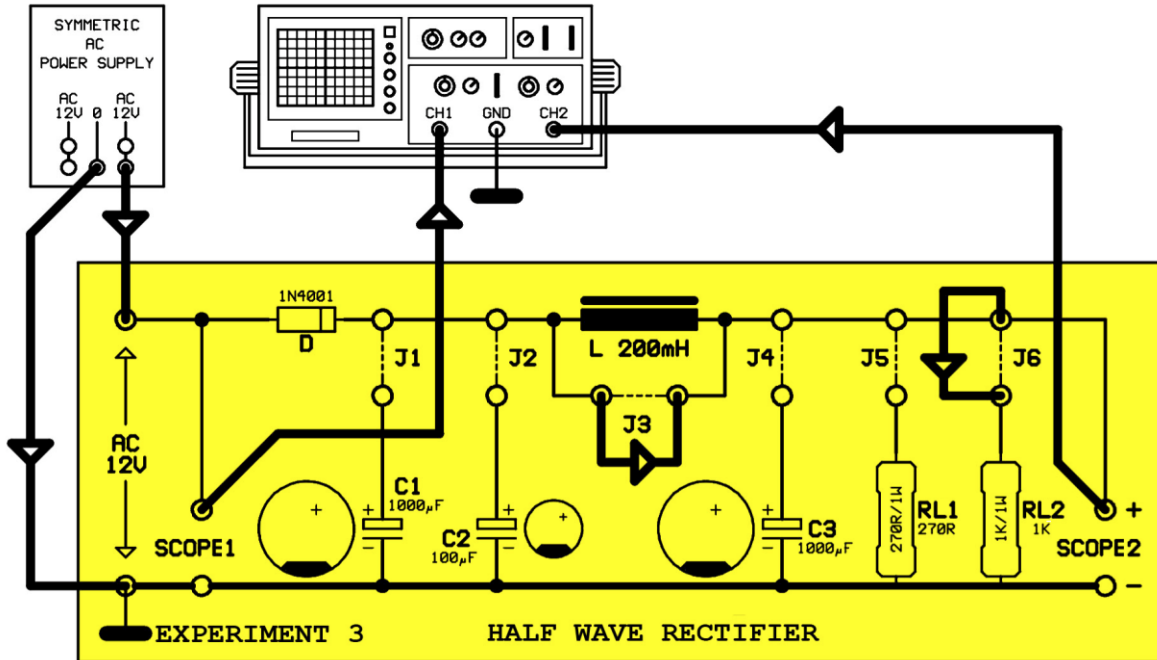

Figure 9

The circuit in Figure 9, although seems to be complicated, is in fact a trivial electrical circuit. The simple structure of the circuit is shown in Figure 10. Except Diode and RL2 resistor, all elements have no effect to the circuit.

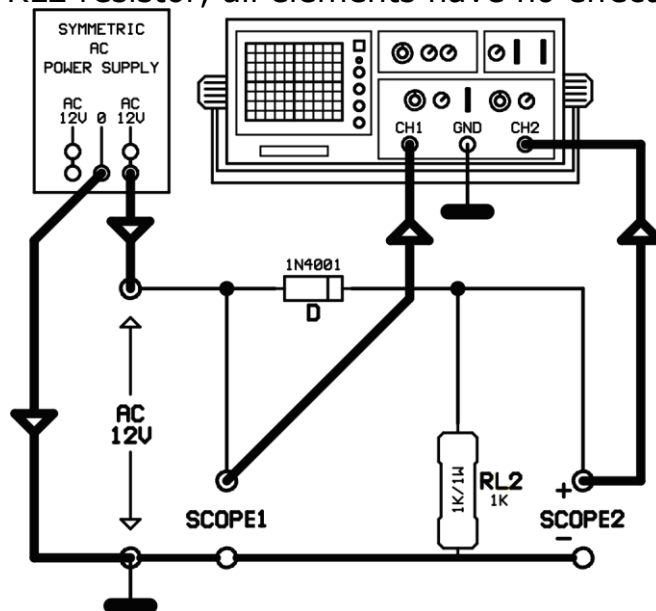

Figure 10

The transformer is not clear in Figure 9. The required alternating voltage is taken from AC 12V/0/AC 12V the alternating power supply in the experiment kit. This supply is the output pins of a middle pinned secondary of a transformer.

1- Apply power to the circuit. Observe and draw the Scope1 (**input**), Scope2 (**output**) signals.

Figure 11

2- When output signal is present with respect to the input signal? Why?

3- Measure input and output voltages by a voltmeter.

V_i =AC	Volt	V_o =DC	Volt.
-----------------------------	------	-----------------------------	-------

4- Compare these measured values by mathematical evaluations.

V_o =

The measured values and evaluated values are

5- Is the output DC voltage usable?

EXPERIMENT: 1.4

EXAMINATION OF A FULL WAVE RECTIFIER

Put Y-0016/005 module in place. Connect the circuit shown in Figure 12.

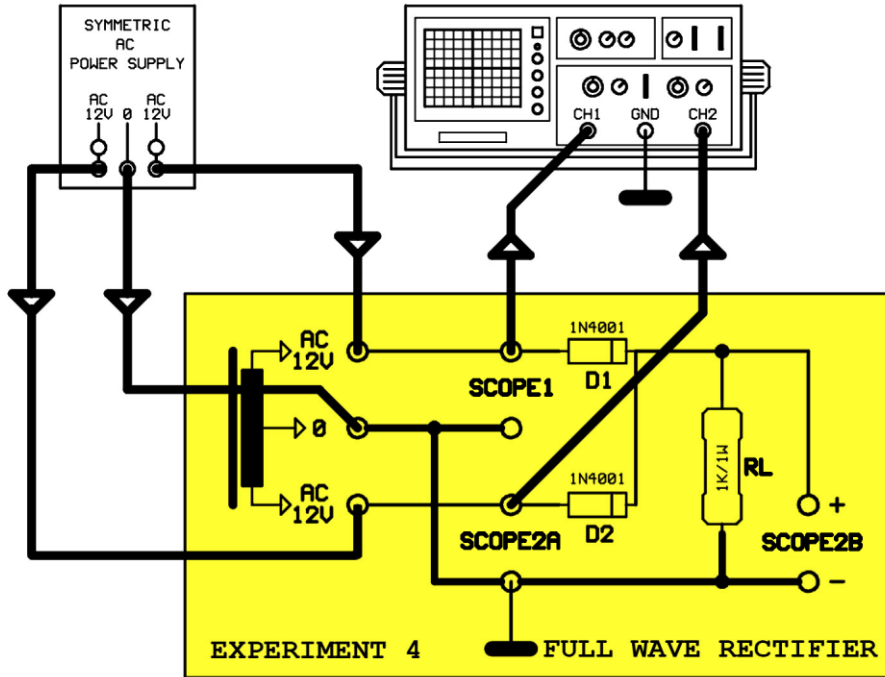

Figure 12

1- Apply power to the circuit. Observe and draw the Scope1 (**input**), Scope2 (**output**) signals. Compare two signals

Figure 13



2- Cut the power to the circuit. Put the SCOPE2A prob to SCOPE2B point. Observe and draw the Scop signals.

Figure 14

3- When is output active? Why?

4- Measure input and output voltages with a voltmeter.

V_i = AC	<i>Volt</i>	V_o = DC	<i>Volt.</i>
------------------------------	-------------	------------------------------	--------------

5- Evaluate the mathematical values of this measured signals. Compare the values.

V_o =

These values are

EXPERIMENT: 1.5

EXAMINATION OF BRIDGE TYPE FULL WAVE RECTIFIER

Put Y-0016/005 module in place. Connect the circuit shown in Figure 15.

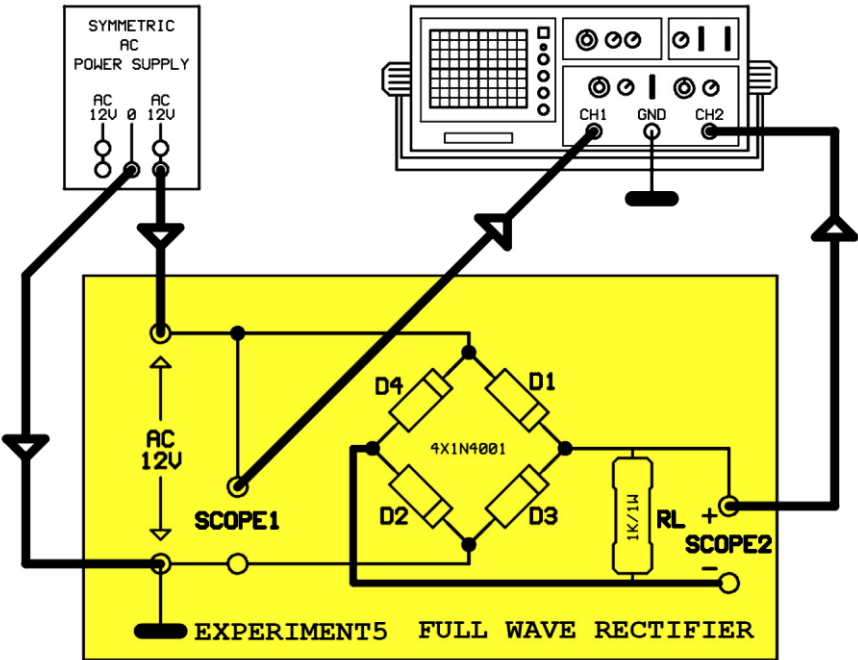

Figure 15

Warning: The ground at the measurement pins are not same.

Take the Scope signal one by one.

1- There is no scope in Scope1 point. What must be the type of the signal at this point?

The signal at point Scope1 is a **signal.**

2- Apply power to the circuit. Observe the output signal at Scope2. When is output signal present with respect to input signal?

Figure 16

The output signal is

Because

3- Measure input and output voltages with a voltmeter.

V_i = AC Volt **V_o** =DC Volt

4- Evaluate the output voltage mathematically and compare that with the measurement.

V_o =

Evaluation and measurement results are.....