

ELECTRONICS LABORATORY

PART 5

Assoc. Prof. Serhan Yarkan

ISTANBUL COMMERCE UNIVERSITY

Contents

CONNECTION TYPES OF TRANSISTOR	2
7.1 INTRODUCTION	2
7.2 FUNCTION GENERATORS.....	3
7.3 EMITTER GROUND (CHASSIS) AMPLIFIER.....	5
7.4 BASE GROUND (CHASSIS) AMPLIFIER.....	6
7.5 COLLECTOR GROUND (CHASSIS) AMPLIFIER	7

CONNECTION TYPES OF TRANSISTOR

7.1 INTRODUCTION

There are some relations between the input and output signals of transistors and input and output resistances (**impedances**) of transistors. It is required to know about these relations in order to connect the transistor to the circuit as an active component (**as an amplifier component**). A good amplifier must not distort the input signals. Any kind of degeneration is called "**distortion**".

Transistors work as current sensitive active components of circuits. It has a closed box shape. There are two input and two output terminals of transistors regardless of their connection type.

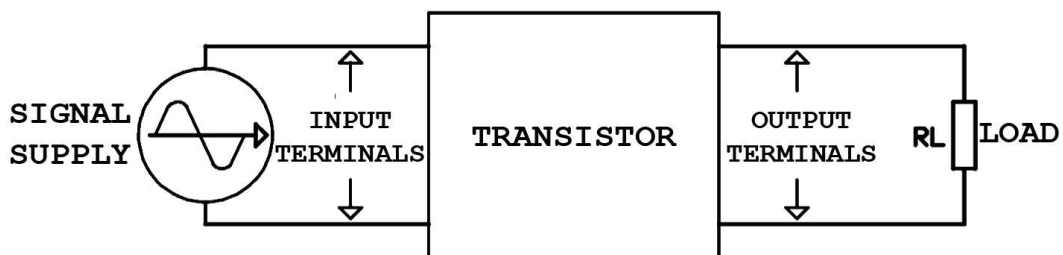

Figure 7. 1

The parameters that are affected by the connection type are as follows:

Input Impedance (Z_i): It is the resistance of transistor to the signal supply. If the input impedance of transistor is too low, then it will draw too much current, then, if the output of signal supply does not have enough current value, the output signal of supply will be distorted. If the input impedance is too-high it can be applicable to any kind of signal supply but sometimes it can result in statics. The selection should be made according to the system properties.

Output Impedance (Z_o): It is the feature that can be connected to the output of transistor, it feeds the supply. If the output impedance is low it can feed any load. If it high it can not feed load or low resistance circuit, the signal is distorted. Connection types with low output impedance is generally used in electric circuits.

Current Gain (β): It is the ratio of current change in the output (I_o) signal to the current change in input signal (I_i).

$$\beta = \frac{\Delta I_o}{\Delta I_i}$$

Current gain is expected to be high at electric circuit.

Voltage Gain (A): It is the ratio of voltage change in the output (V_o) signal to the voltage change in input signal (V_i).

$$A = \frac{V_o}{V_i}$$

Power Gain: simply, it is the multiplication of current gain and voltage gain.

There are three types of connection for transistors when they work as active component in circuit.

- 1- Emitter Grounded Amplifier
- 2- Base Grounded Amplifier
- 3- Collector Grounded Amplifier

Amplifiers assess the input signal as voltage or current depending on the connection types. Forms and properties of these three connections will be examined respectively.

7.2 FUNCTION GENERATORS

These devices generate various types of waveforms. One of the most used waveforms is the sine wave which is used in analog circuits. Another one is the "TTL (Transistor-Transistor Logic)" known as square wave; it is used in digital circuits and has amplitude of "0" and +5Volt. The function generator in our experiment set can generate these waveforms; it can also generate triangle wave. We have previously seen the sine wave. Triangle and square (TTL) are shown in Figure 7. 2.

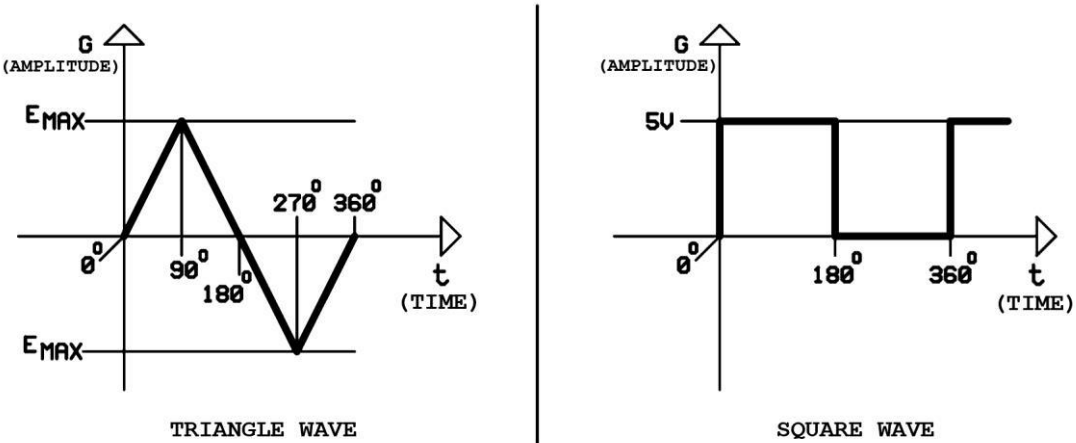

Figure 7. 2

Front panel of the function generator in our set is shown in Figure 7. 3

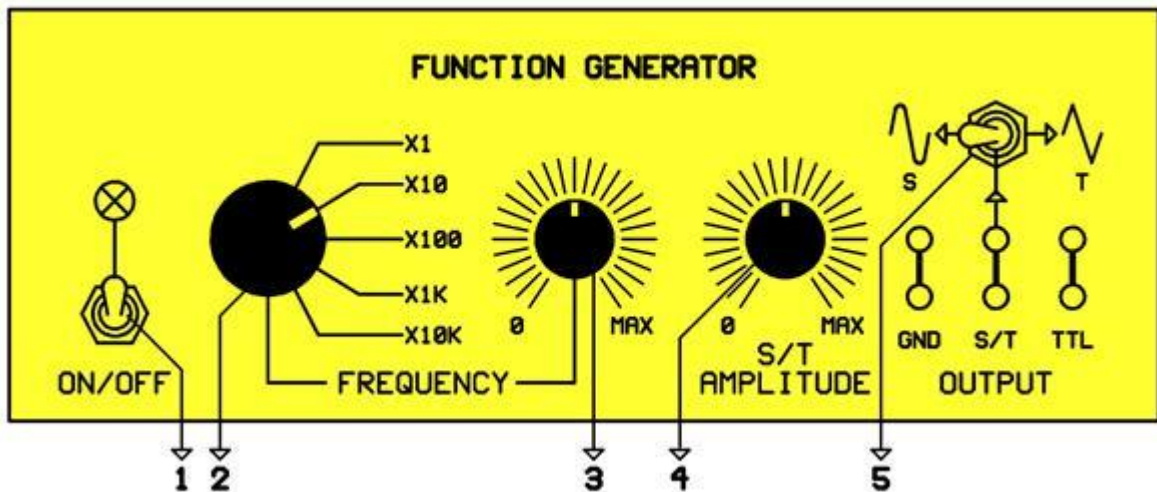

Figure 7. 3

Control components on the front panel are enumerated. Functions of control components are as follows:

1- Power on-off: It is the switch used to turn on the function generator. The led turns on with this switch.

2- Frequency rotary switch: It is a five-level commutator to select frequency limits of the generated signal. Output signal frequencies for every level are:

- X1 = 1Hz-10Hz
- X10 = 10Hz-100Hz
- X100 = 100Hz-1KHz
- X1K = 1KHz-10KHz
- X10K = 10KHz-100KHz

3- Frequency potentiometer: It is the potentiometer which is used to adjust the output signal frequency to sub-levels between the limits adjusted by frequency rotary switch.

4- Amplitude potentiometer: It adjusts the output signal amplitude between $V_{pp}=0\text{Volt}$ and 10Volt

5- Waveform switch: It is the switch used to select the form (**sine-triangle-square**) of output signal. Sine and triangle waves are taken from the socket in the middle and square is taken from the socket at right.

7.3 EMITTER GROUND (CHASSIS) AMPLIFIER

Emitter ground amplifier, its input and output forms are shown in Figure 7. 4. It is the most commonly used connection type.

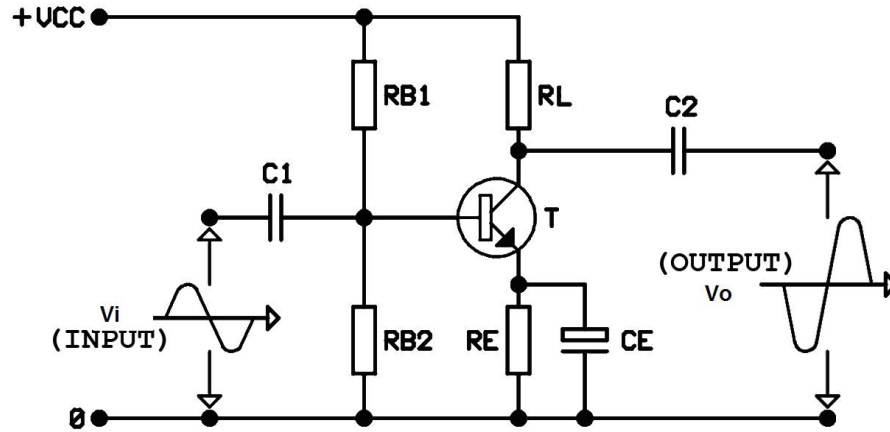

Figure 7. 4

Input signal is applied to base by the help of C1 in this circuit. Output signal is taken from collector by the help of C2. A constant DC bias is applied to the base in this circuit. DC bias is provided by RB1 and RB2 resistors, and Vcc supply. Because of this, transistor is conducting even if the amplifier and AC input signal is not applied. There is always power consumption in the circuit. RE is the feedback resistor. It restricts the extreme increases in collector current. CE capacitor increases the gain.

When the AC signal is applied to the input of amplifier, base voltage increases at positive alternation of AC signal because the directions of positive alternation of AC signal and DC bias voltage are the same and they are added to each other. This total voltage is applied to the base-emitter and conductance of transistor increases. Thus, the collector current increases. Voltage on the terminals of RL load resistor increases with the increase in collector current. So, the output voltage decreases because the voltages of AC signal and DC bias are in opposite directions. In that situation, conductance of transistor (collector current) decreases. Output voltage increases and this process means that there is a phase difference of 180° between input and output signals of emitter ground amplifiers.

The properties of emitter ground connection type are as follows:

- a-** Input impedance has middle value (**50K**).
- b-** Output impedance has middle value (**50K**).
- c-** Voltage gain is high.
- d-** Current gain is high
- e-** There is a medium power gain.

7.4 BASE GROUND (CHASSIS) AMPLIFIER

Input signal is applied to the emitter terminals in base ground amplifiers. Output signal is taken from the collector by the help of a capacitor. In such circuits, base-emitter is forward biased and base collector is inverse biased. Base ground amplifier circuit is seen in Figure 7. 5.

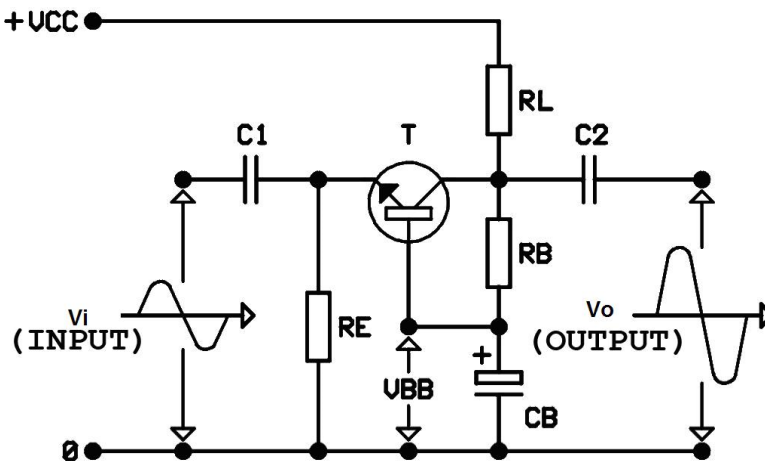

Figure 7. 5

Collector bias is fed by a power supply (V_{CC}). Base bias (V_{BB}) is maintained by an electrolytic capacitor placed between base and chassis. (+) plate of this capacitor is charged over R_B resistor.

When the AC signal is applied to the input of amplifier, base-emitter voltage increases at the positive alternation of AC signal because the directions of AC signal positive alternation and V_{BB} voltage are the same and added to each other. This total voltage is applied to base-emitter and transistor's conductance and collector current increases thus the current passing through R_L load resistor increases. Base-emitter bias voltage decreases at the negative alternation of AC signal because AC signal and V_{BB} voltage have opposite directions. AC signal decreases the base-emitter bias voltage by decreasing V_{BB} voltage. Conductance of transistor decreases and collector-emitter current decreases. Output signal decreases. This process means that input and output signals are mono-phased (are in the same phase) in base ground amplifiers.

The properties of base ground amplifiers are as follows:

- a-** Input impedance is too low (**10R**).
- b-** Output impedance is very high (**1M**).
- c-** Voltage gain is high.
- d-** Current gain is lower than 1.
- e-** Power gain is high.

7.5 COLLECTOR GROUND (CHASSIS) AMPLIFIER

Collector ground amplifier circuit and the forms of its input and output signal waves are shown in Figure 7. 6.

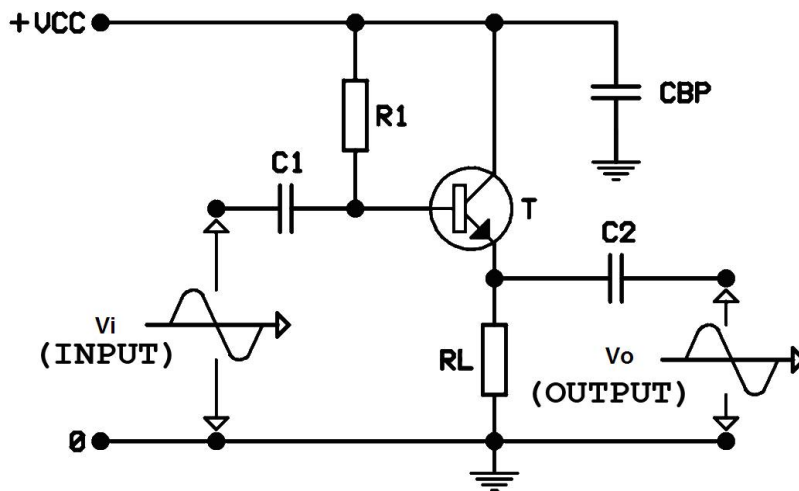

Figure 7. 6

Input signal is applied to base. Output signal is taken from the terminals of emitter resistor (**Load resistance is formed here**). Collector is connected to the related terminal (**according to the type of connection**) of battery. A by-pass capacitor is used to isolate collector from AC.

Input AC signal is applied to the base. In this circuit, base-emitter bias decreases in the positive alternation of input signal. Emitter current decreases because of base current. Positiveness of output signal increases because it is taken by the emitter resistance. Base-emitter bias and emitter current increases in the negative alternation of input signal. Thus, negativity of emitter increases. This process means that input and output signals are on the same phase at collector ground amplifiers.

The properties of collector ground amplifiers are as follows:

- a- Input impedance is high. (**50K-250K**)
- b- Output impedance is low. (**20R-1K**)
- c- Voltage gain is close to 1 but lower than 1.
- d- Current gain (β) is high. (**20-50**)
- e- Power gain is low.

Generally, collector ground amplifier is used as impedance adapter because it does not affect signal supply and it can feed any load because of its low output impedance.