

ELECTRONICS LABORATORY

PART 8

Assoc. Prof. Serhan Yarkan

ISTANBUL COMMERCE UNIVERSITY

Contents

FIELD EFFECT TRANSISTORS.....	2
8.1 MOSFETS.....	2
8.2 INPUT CHARACTERISTICS OF E-MOSFET.....	4
8.3 OUTPUT CHARACTERISTICS OF E-MOSFET.....	5
8.4 OPERATION OF E-MOSFET.	6

FIELD EFFECT TRANSISTORS

8.1 MOSFET'S

MOSFET is the abbreviation for **Metal-Oxide Semiconductor Field Effect Transistor**. MOSFETs are like JFETs in many ways. For example, their terminals are named as drain, gate and source. Channel conductance is controlled by VGS (**gate-source voltage**). The most important difference between MOSFETs and JFETs is that gates of MOSFETs are isolated from the channel region. Therefore, the input impedances of MOSFETs are higher than JFETs and BJTs. Input impedances of MOSFETs are approximately 10^{14} ohm. Signal source is never affected because of that. MOSFETs are also called IGFET.

MOSFETs are structured over a lower stratum. This stratum is called "**SUBSTRATE=SUB**". SUB is shown as terminal in schematic symbols. Channel type of MOSFET is determined by the direction of the arrow on that terminal.

MOSFETs are produced in two types in terms of structure. The difference of structure also affects the channel conductance of MOSFET. Because of that, there are two types of MOSFETs:

1-Depletion type MOSFET

2-Enhancement type MOSFET

Shortly, depletion type is called D-MOSFET and enhancement type is called E-MOSFET.

Channels are created physically in D-MOSFETs. When there is no voltage in gate terminal, if a voltage is applied between drain and source, and then drain-source current passes flows in D-MOSFETs. Also, channels cannot be created in the production level of E-MOSFETs. In order to flow drain-source current, it is required to apply a voltage to gate terminal.

There are N and P channel types of MOSFETs. MOSFETs are commonly used in electronics because they have two gates (**DUAL GATE**). When the signal is applied to one gate, the gain can be controlled by applying a bias to another gate. Dual gate MOSFETs can be used as mono-gate by unifying two gates.

MOSFETs are especially used as driver amplifier in high power controls. High power MOSFETs are called POWER MOSFETs. Channel structure of these MOSFETs is wider, so they can control higher channel currents. They are also called VERTICAL MOSFET or shortly V-MOSFET.

MOSFETs can be affected by static electric and breakdown. In order to minimize the effects of static electric, Zener diode is placed between gate and source terminals.

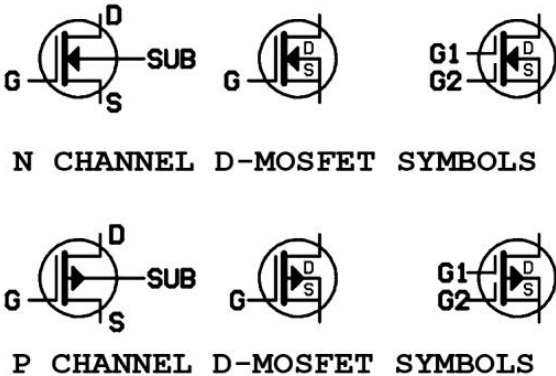

Figure 8.1

Various symbols of N and P channeled D-MOSFET are shown in figure 8.1. The direction of the arrow on the SUB terminal determines the type of D-MOSFET. The direction of the arrow is inwards in N type and outwards in P type. Let's see how D-MOSFET works under various DC bias voltages on figure 8.2

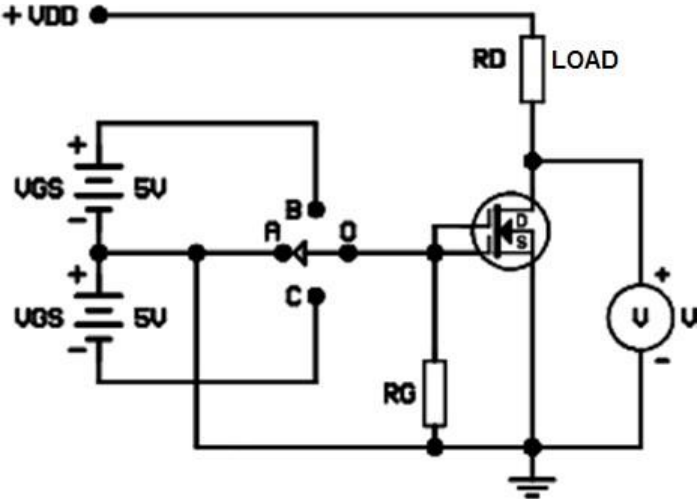

Figure 8.2

In figure 8.2, N type dual gate D-MOSFET is converted to a mono-gate D-MOSFET. If $V_{GS}=0$ (**points OA short-circuited**), then D-MOSFET starts transmission. Supply voltage is shared between R_D resistor and D-MOSFET. This operation is in depletion region. If $V_{GS}=+5V$, then the drain current (I_D) of D-MOSFET reaches maximum value. At that moment D-MOSFET is saturated. Its resistance is at minimum and the voltage on it is at minimum. If V_{GS} voltage is made negative drain current (I_D) decreases. This operation is enhancement region. If $V_{GS}=-5V$ (**points OC short circuited**), the resistance of D-MOSFET increases too much. At that moment drain current is zero (**0**) and D-MOSFET goes to **CUT-OFF**; so, supply voltage is equal to V_{DS} voltage. Practically, D-MOSFETs are not used because drain current (I_D) continues to flow even if there is no signal at the gate.

8.2 INPUT CHARACTERISTICS OF E-MOSFET

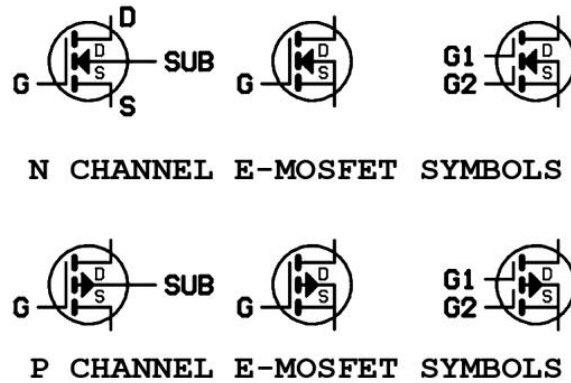

Figure 8.3

In figure 8.3, various symbols of N and P channel E-MOSFETs are shown. The direction of arrow on SUB terminal determines the type of E-MOSFET. N type E-MOSFET is used in the experiment because it is the most commonly used one. As we know, V-MOSFETs are used in high power circuits. Resistances of V-MOSFETs are very low at saturation. So, the voltage on them will be very low, too.

Input characteristics of E-MOSFET is the curve showing the effect of variable input voltages to output current, when the V_{DS} (**drain-source voltage**) is constant.

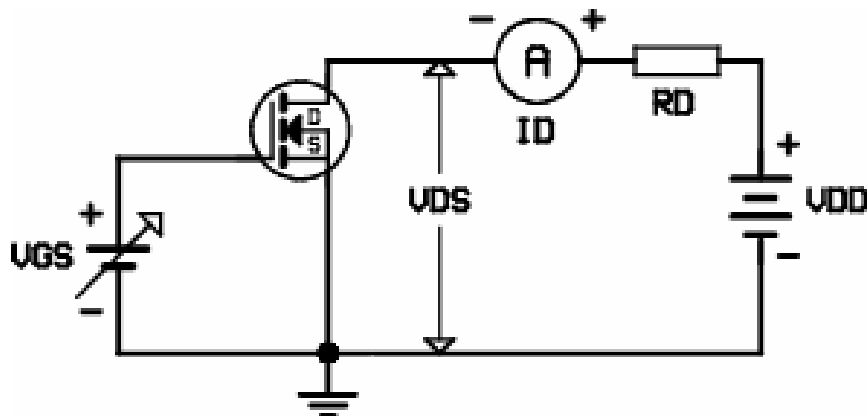

Figure 8.4

Input characteristics of E-MOSFET can be derived by using the circuit on figure 8.4; R_D resistor in the circuit is used to restrict the drain current. If R_D resistor is not used, V-MOSFET reaches saturation point at a specific V_{GS} voltage and drain current increases rapidly, so the transistor can be harmed.

8.3 OUTPUT CHARACTERISTICS OF E-MOSFET

Output characteristics of E-MOSFET is the curve which shows the effects of variable V_{DS} (**drain-source voltage**) to output current when the V_{GS} (**Gate-source voltage**) is constant.

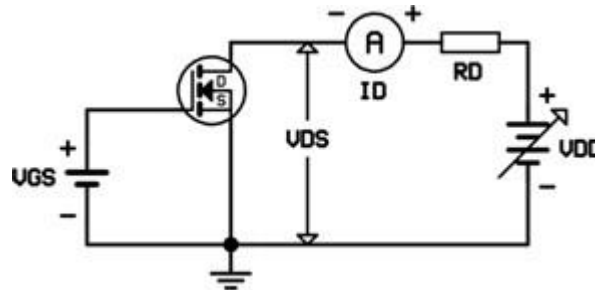

Figure 8.5

In figure 8.5, R_D resistor is used for restricting the drain current. If R_D resistor is not used, V-MOSFET reaches saturation point at a specific V_{GS} voltage and drain current increases rapidly, so the transistor can be harmed.

8.4 OPERATION OF E-MOSFET

The purpose of the experiment is to show how E-MOSFET operates under variable DC bias voltages.

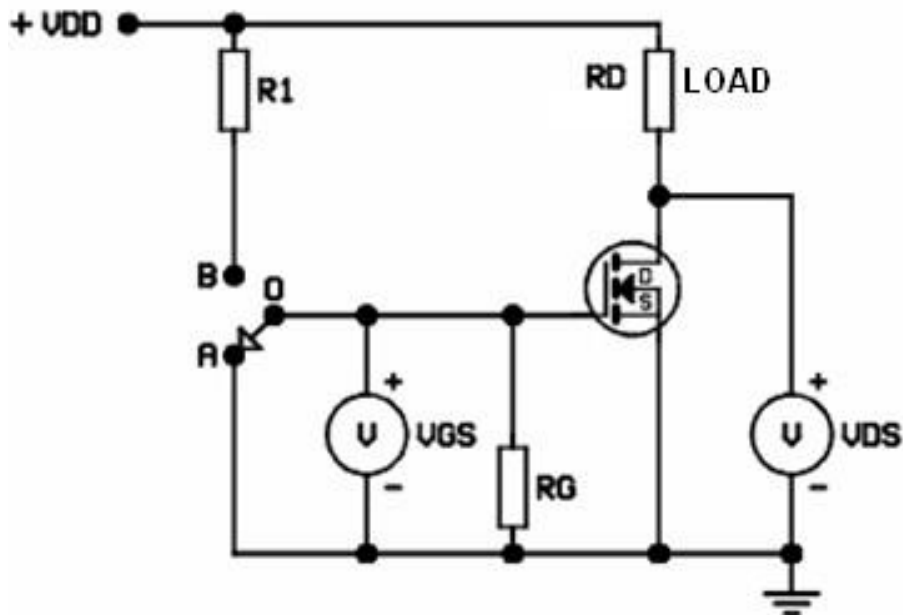

Figure 8.6

In figure 8.6, if $V_{GS}=0$, (**points OA short circuited**) then the drain current (I_D) of E-MOSFET is also zero (0). E-MOSFET is cut-off at that moment. This is the most important difference between E-MOSFETs and D-MOSFETs. Drain current flows in D-MOSFETs when $V_{GS}=0$. If V_{GS} is made positive enough in forward direction (**points OA short circuited**) then drain current rapidly increases and E-MOSFET reaches saturation point. In other words, it is required to apply forward bias to the gates of E-MOSFET to make sure that they start transmission and reach saturation.