

ELECTROTECHNICH LAB.

PART 2 EXPERIMENTS

Yrd. Doç. Dr. Taha İMECİ

Arş. Gör. Ezgi YAMAÇ

Arş. Gör. Ufuk ŞANVER

İSTANBUL COMMERCE UNIVERSITY

Contents

EXPERIMENT: 5.1	2
ANALYZING THE THEVENIN THEOREM	2
EXPERIMENT: 5.2	5
ANALYZING THE NORTON THEOREM.....	5
EXPERIMENT: 6.1	8
EXAMINATION OF SERIAL CONNECTED COILS.....	8
EXPERIMENT: 6.2	9
EXAMINATION OF PARALLEL CONNECTED COILS	9
EXPERIMENT: 6.3	10
EXAMINATION OF MIXED CONNECTED COILS	10
EXPERIMENT:7.1	12
EXAMINATION OF SERIAL CONNECTED CAPACITORS	12
EXPERIMENT: 7.2	13
EXAMINATION OF PARALLEL CONNECTED CAPACITORS.....	13
EXPERIMENT: 7.3	14
EXAMINATION OF MIXED CONNECTED CAPACITORS	14

EXPERIMENT: 5.1

ANALYZING THE THEVENIN THEOREM

EXPERIMENTAI PROCEDURE:

Connect the Y-0016/004 module to its place. Before making the circuit connections, give energy to the set and adjust the power supply voltage to 6V. Cut off the energy of the set. Make the circuit connection as in Figure 5.14. Give energy to the circuit.

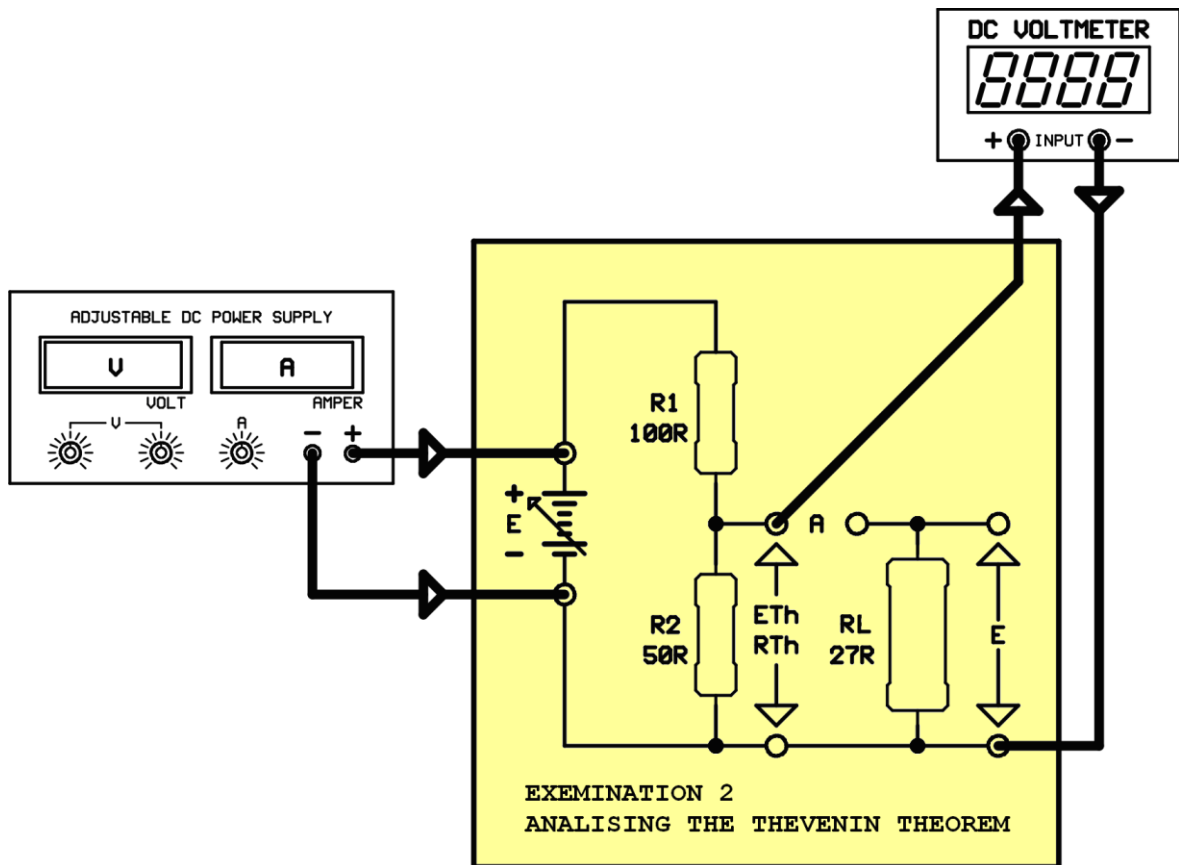

Figure 5.14

- 1- What is the voltage seen on the voltmeter in Figure 5.14 called? Read and note this voltage.

- 2- Mathematically calculate the Thevenin voltage. Compare the values that you calculated and you measured.

- 3- Remove the voltmeter and the "E" source from the circuit. Short circuit the source sockets in the circuit. At this moment, measure the resistance of the R2 resistor using an ohmmeter. What is this resistance called? Read and note the value seen on the ohmmeter.

- 4- Mathematically calculate the Thevenin resistance. Compare the values that you calculated and you measured.

- 5-Construct the Thevenin Equivalent of the circuit with the values you found.

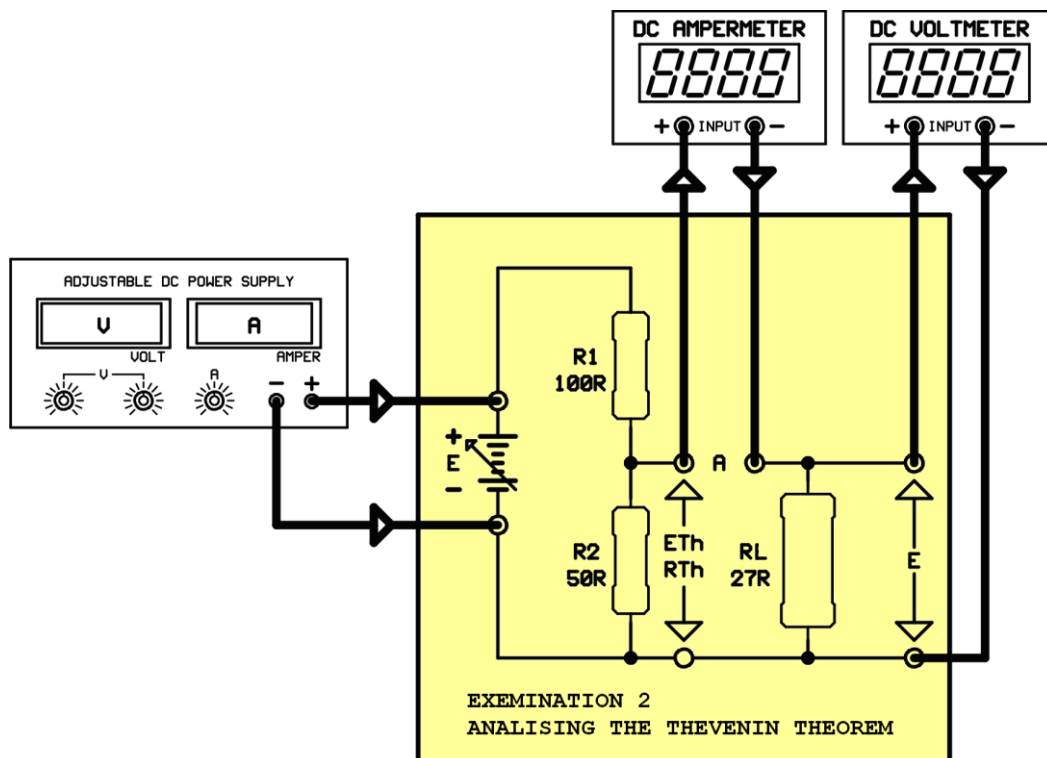
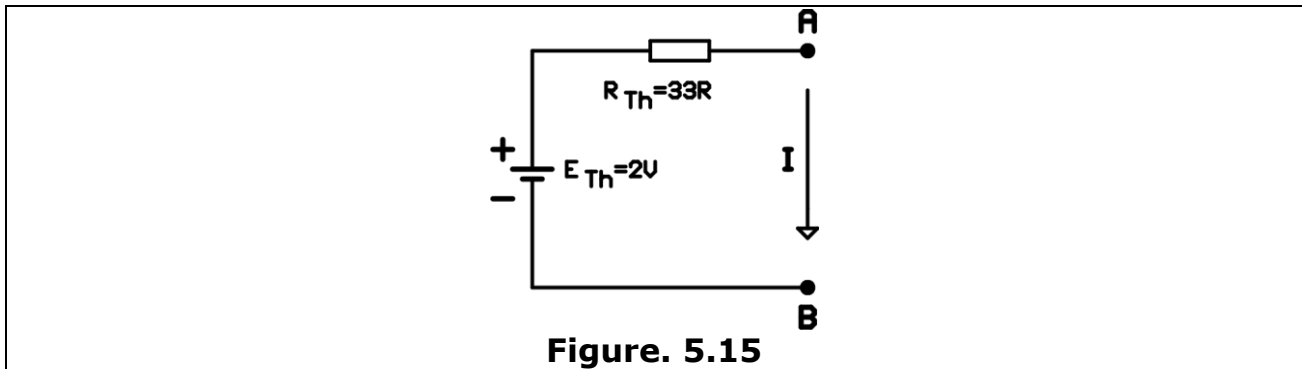

5- Make the circuit connections as in Figure 5.16. Read and note the voltage on the load and the current passing through the load.

6- Mathematically calculate the voltage on the load and the current passing through the load. Compare the values you measured and you calculated.

8- If we see a mismatch between the value calculated and the value read, what can be the reason for this?

EXPERIMENT: 5.2

ANALYZING THE NORTON THEOREM

EXPERIMENTAL PROCEDURE:

Connect the Y-0016/004 module to its place. Before making the circuit connections, give energy to the set and adjust the power supply voltage to 6V. Cut off the energy of the set. Make the circuit connection as in Figure 5.23. Give energy to the circuit.

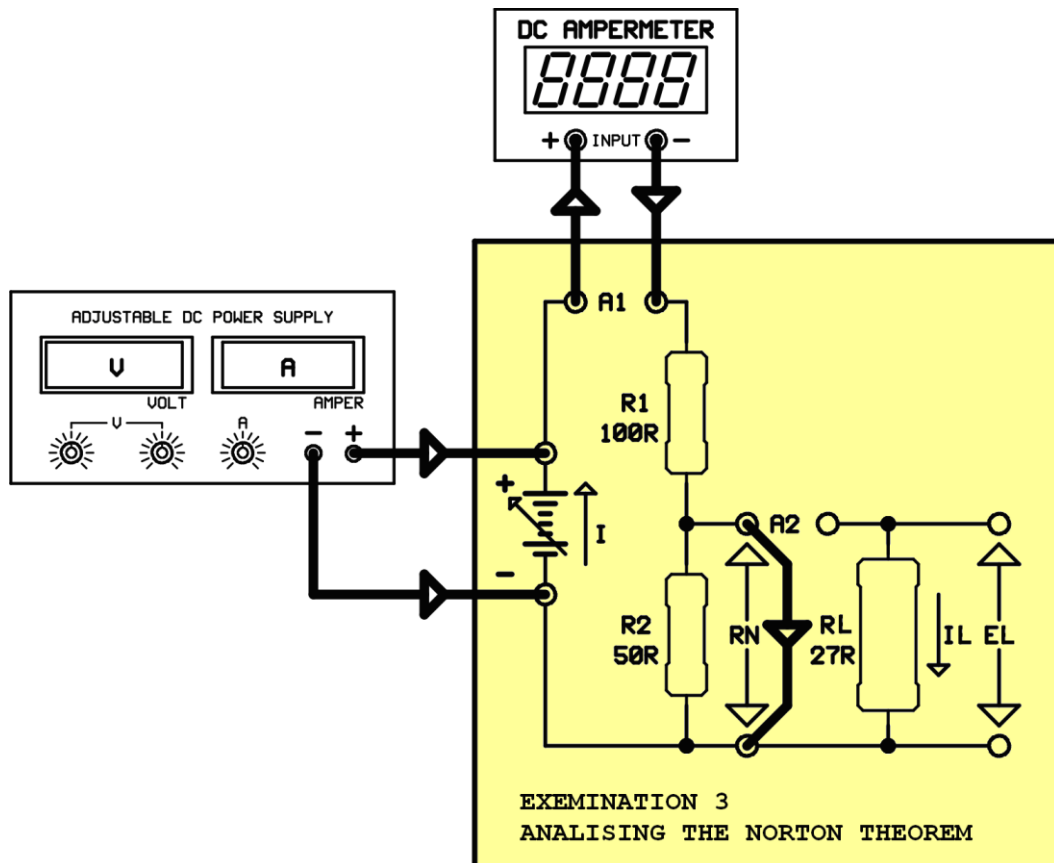

Figure 5.23

1- What is the current seen on the ammeter in Figure 5.23 called? Read and note this current.

2- Mathematically calculate the Norton current. Compare the values you calculated and measured.

3- Remove the ammeter and the source from the circuit. Short circuit A1 and the source sockets in the circuit. Open the short circuit across the terminals of the R2 resistor. Read the resistance across the R2 resistor using an ohmmeter. What is this resistor called? Note the resistance seen on the ohmmeter..

4- Mathematically calculate the Norton resistance. Compare the values you calculated and read on the ohmmeter.

5- Draw the Norton equivalent circuit with the values found.

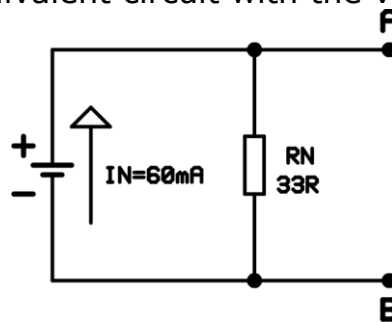

Figure 5.24

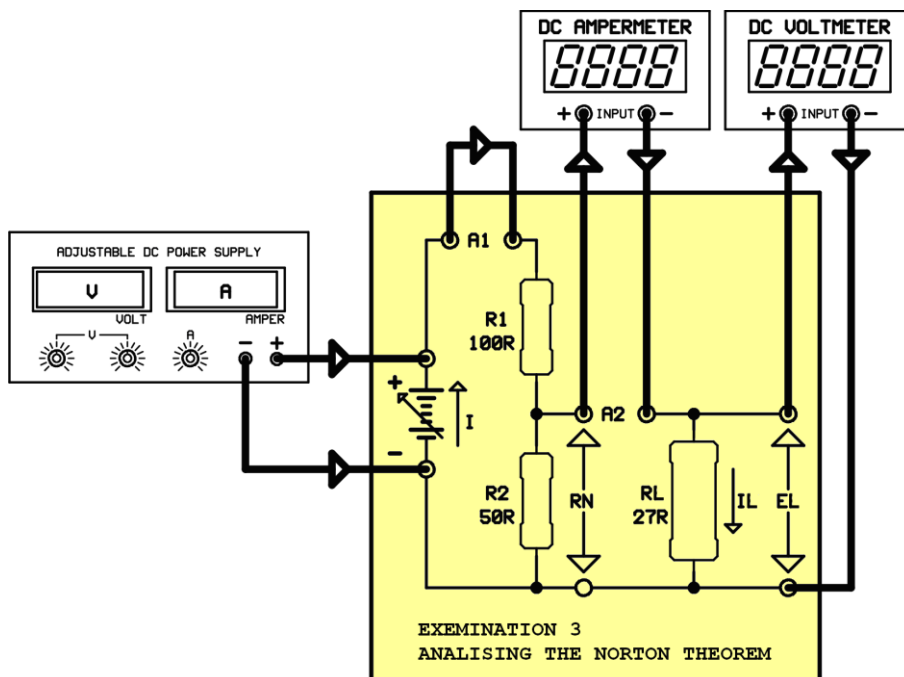

Figure 5.25

6- Make the circuit connections as in Figure 5.25. Read and note the voltage on the load and the current passing through the load.

7- Mathematically calculate the current passing through the load and the voltage on the load. Compare the values you calculated and measured.

7- If we see a mismatch between the value calculated and the value read, what can be the reason for this?

EXPERIMENT: 6.1

EXAMINATION OF SERIAL CONNECTED COILS

EXPERIMENTAL PROCEDURE:

Plug the Y-0016/003 module. Make the circuit connection as in 6.28

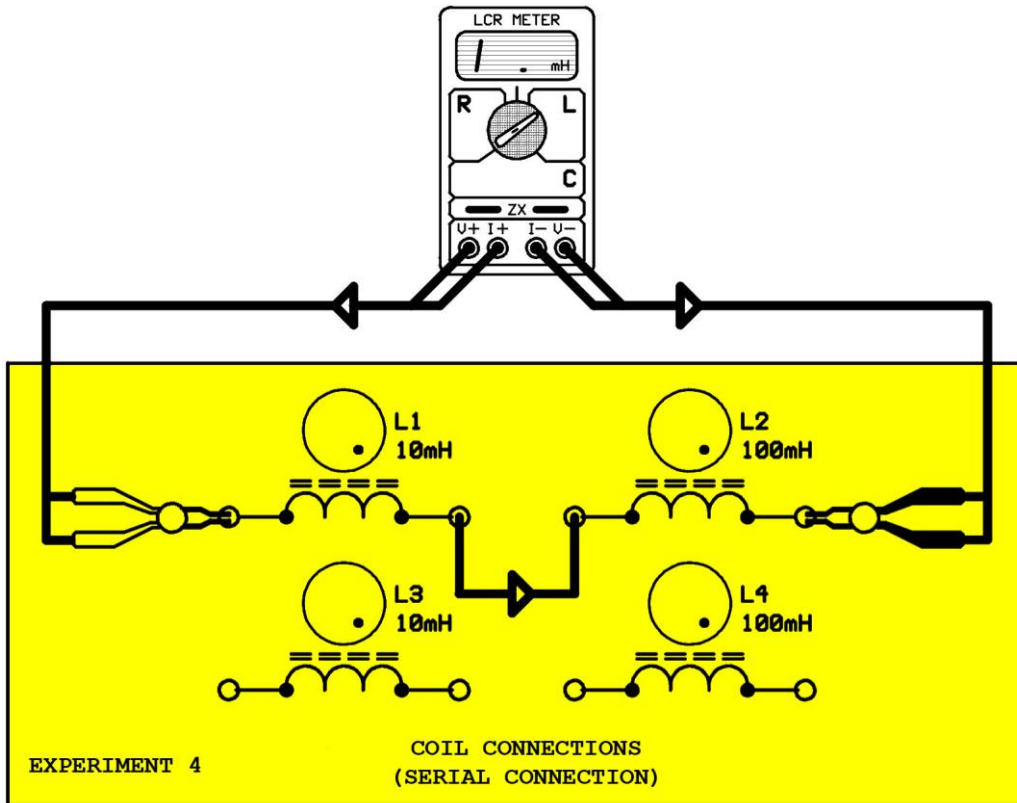

Figure 6.28

1- Write the inductance value displayed by LCR meter

2- $L_1=10\text{mH}$, $L_2=100\text{mH}$, calculate the total inductance of the circuit.

3- Compare the value you calculated and the value displayed by LCR meter. Why is there a difference?

NOTE: You can do new experiments by making different serial connections with the four coils in the module.

EXPERIMENT: 6.2

EXAMINATION OF PARALLEL CONNECTED COILS

EXPERIMENTAL PROCEDURE:

Plug the Y-0016/003 Module. Make the circuit connections as in figure 6.31

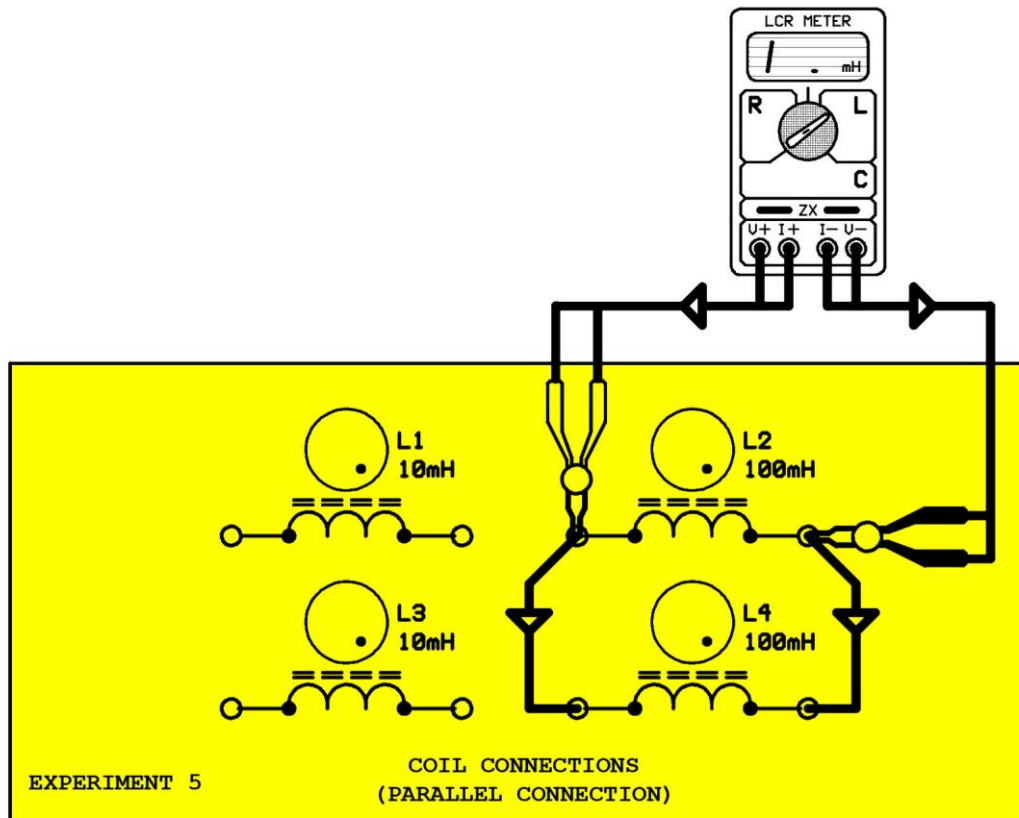

Figure 6.31

1- Write the inductance value displayed by LCR meter

2- $L_2=100\text{mH}$, $L_4=100\text{mH}$, calculate the total inductance of the circuit.

3- Compare the value you calculated and the value displayed by LCR meter. Why is there a difference?

NOT: You can do new experiments by making different parallel connections with the four coils in the module.

EXPERIMENT: 6.3

EXAMINATION OF MIXED CONNECTED COILS

EXPERIMENTAL PROCEDURE:

Plug the Y-0016/003 Module. Make the circuit connections as in figure 6.34

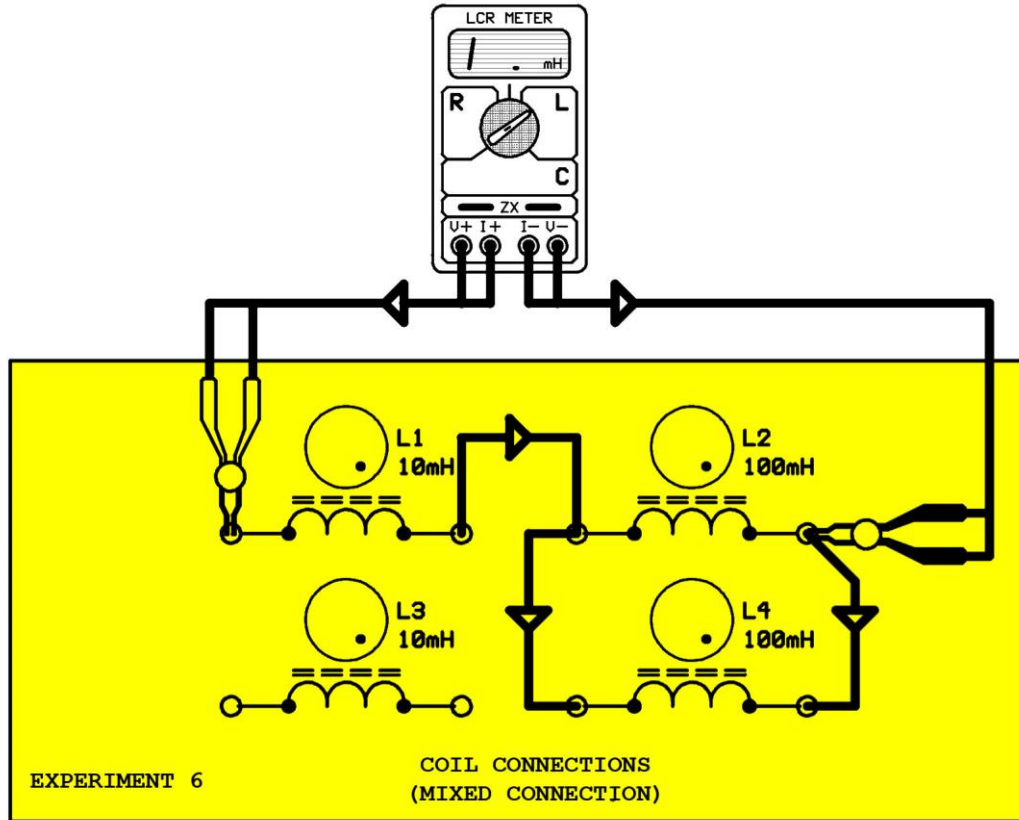

Figure 5.34

1- Write the inductance value displayed by LCR meter.

2- $L_1=10\text{mH}$, $L_2=100\text{mH}$ and $L_3=100\text{mH}$, calculate the total inductance of the circuit

3- Compare the value you calculated and the value displayed by LCR meter. Why is there a difference?

NOT: You can do new experiments by making different mixed connections with the four coils in the module.

EXPERIMENT:7.1

EXAMINATION OF SERIAL CONNECTED CAPACITORS

EXPERIMENTAL PROCEDURE:

Connect the Y-0016/003 module to the board. Make the circuit connections as in figure 7.17.

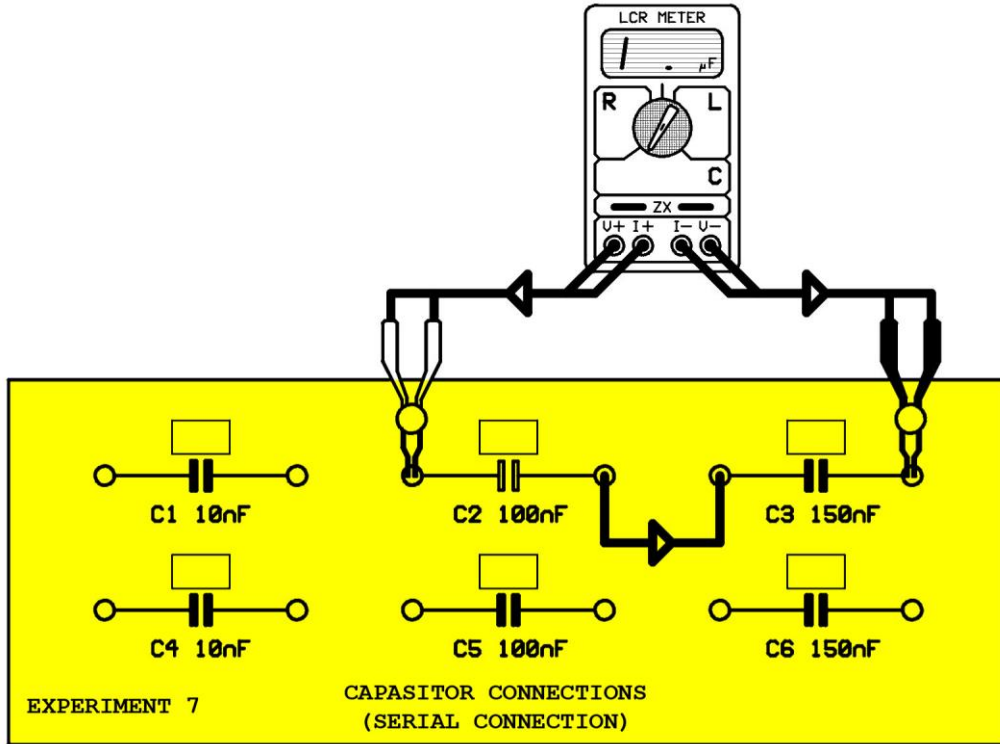

Figure 7.17

1- Write the value that you read on the LCR meter.

2- Calculate the total capacitance of the circuit

3- Compare the capacitance value that you read on the LCR meter and the calculated. What is the reason of the difference?

NOTE:Make new experiments by serial connecting different capacitors using the ones in the module.

EXPERIMENT: 7.2

EXAMINATION OF PARALLEL CONNECTED CAPACITORS

EXPERIMENTAL PROCEDURE:

Connect the Y-0016/003 module to the board. Make the circuit connections as in figure 7.21.

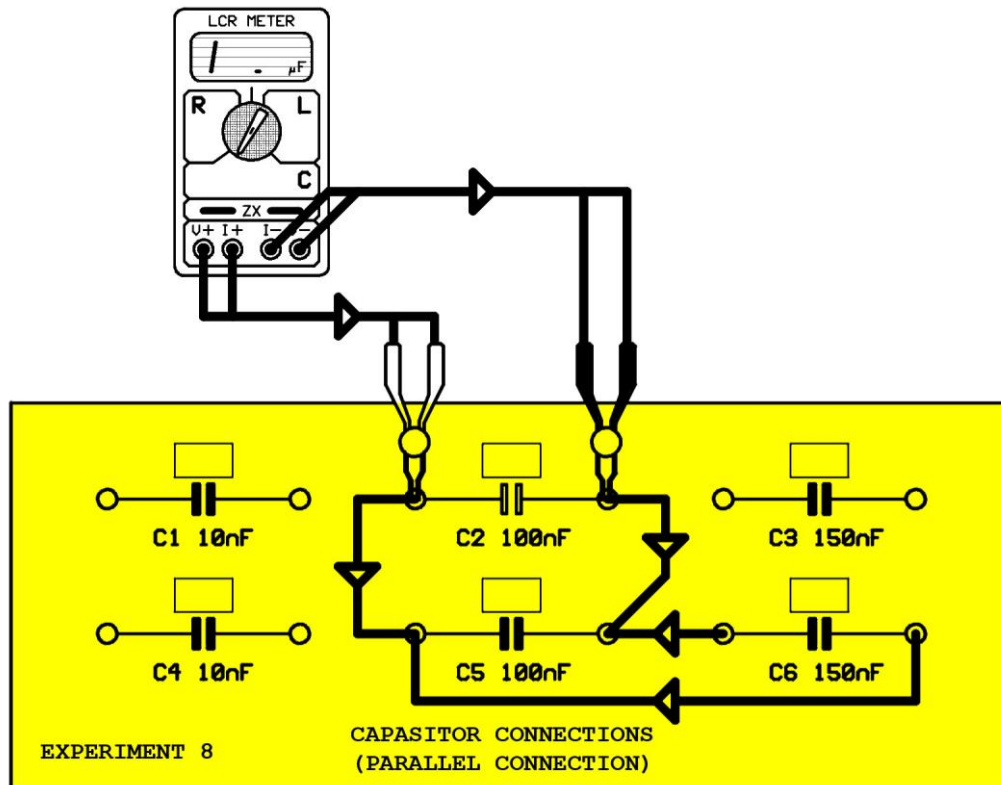

Figure 7.21

1- Write the value that you read on the LCR meter.

2- Calculate the total capacitance of the circuit

3- Compare the capacitance value that you read on the LCR meter and the calculated. What is the reason of the difference?

NOTE: Make new experiments by parallel connecting different capacitors using the ones in the module.

EXPERIMENT: 7.3

EXAMINATION OF MIXED CONNECTED CAPACITORS

EXPERIMENTAL PROCEDURE:

Connect the Y-0016/003 module to the board. Make the circuit connections as shown in figure 7.24.

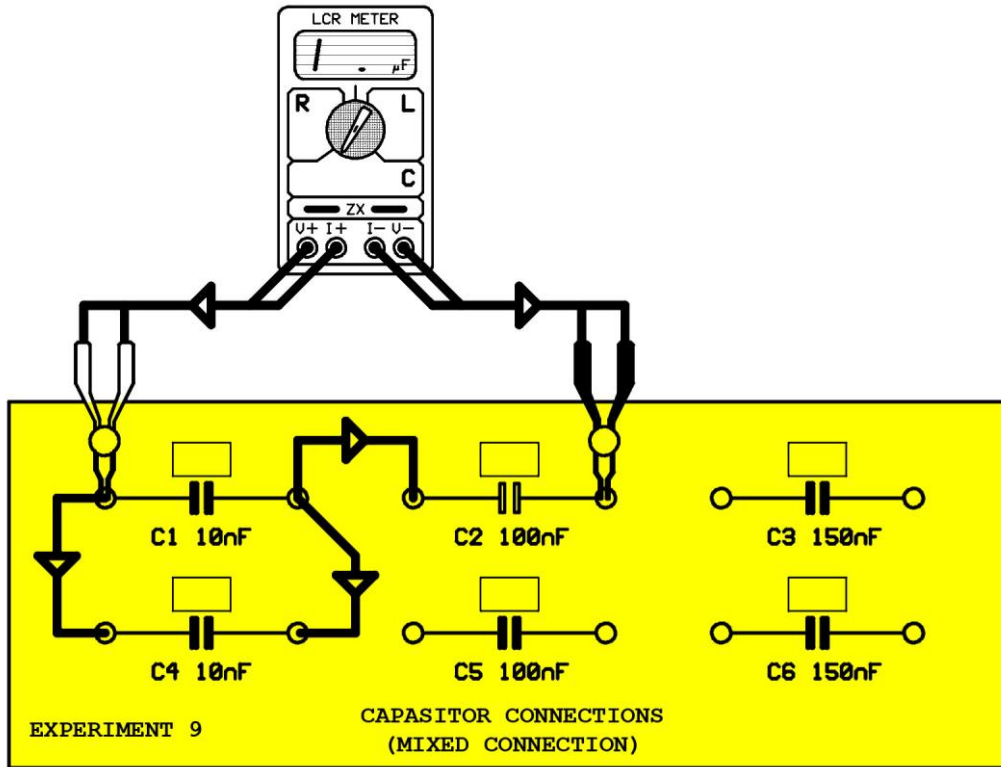

Figure 7.24

1- Write the value that you read on the LCR meter.

2- Calculate the total capacitance of the circuit

3- Compare the capacitance value that you read on the LCR meter and the calculated. What is the reason of the difference?

NOTE: Make new experiments by mix connecting different capacitors using the ones in the module.