

ELECTRONICS LAB.

PART 2 EXPERIMENTS

Yrd. Doç. Dr. Taha İMECİ

Arş. Gör. Ezgi YAMAÇ

Arş. Gör. Ufuk ŞANVER

İSTANBUL COMMERCE UNIVERSITY

Contents

EXPERIMENT: 2.1	2
EXAMINATION OF A CAPACITOR FILTER	2
EXPERIMENT: 2.2	4
ANALYZING LOAD CURRENT'S EFFECT TO THE FILTER.....	4
EXPERIMENT: 2.3	6
ANALYSIS OF π TYPE FILTER.....	6
EXPERIMENT: 2.4	8
EXAMINATION OF VOLTAGE DOUBLER.....	8
EXPERIMENT: 2.5	9
EXAMINATION OF VOLTAGE TRIPPLER.....	9
EXPERIMENT: 2.6	10
EXAMINATION OF VOLTAGE QUADRUPLER	10

EXPERIMENT: 2.1

EXAMINATION OF A CAPACITOR FILTER

EXPERIMENT:

Put Y-0016/005 module in place. Connect the circuit shown in Figure 10.7.

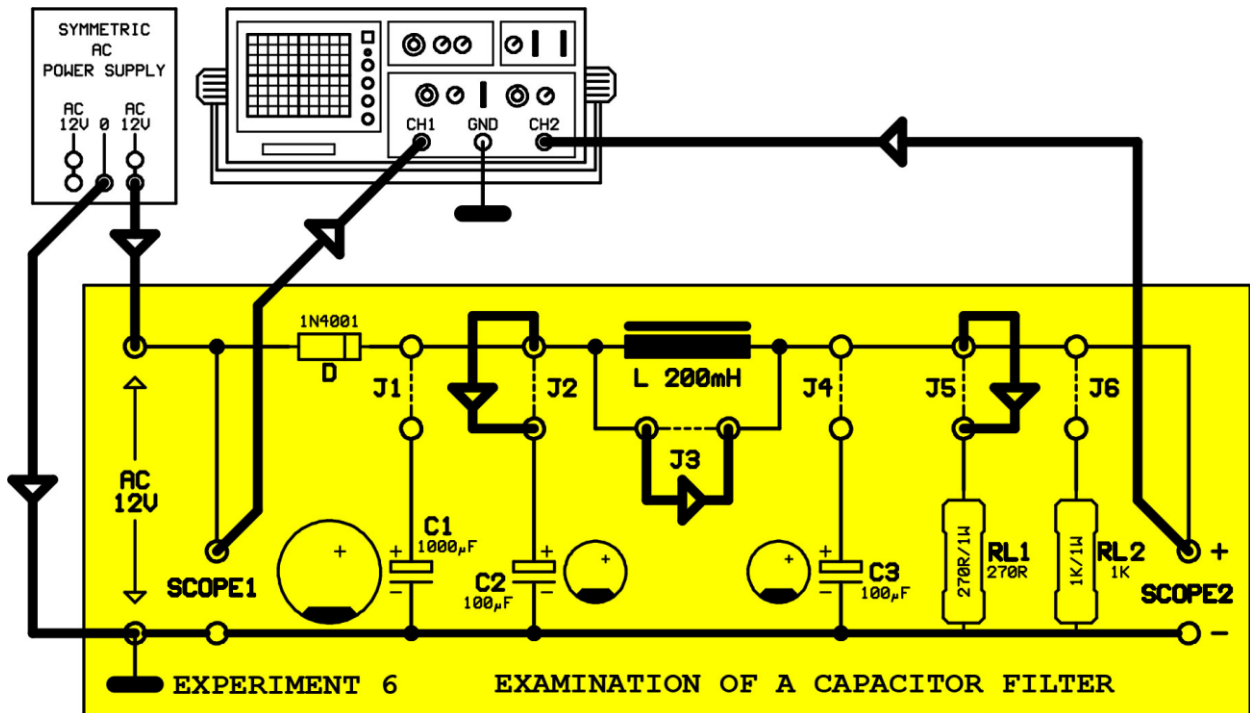

Figure 10.7

Not: J2, J3 and J5 points are short-circuited. At this point, RL1 resistor is circuit load. 100µF electrolytic capacitor is connected parallel to circuit load.

1-Apply power to the scope. Is there a ripple in the Scope? If yes, measure approximately.

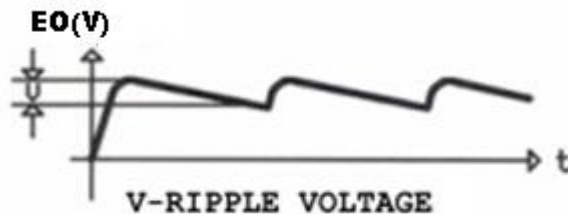

Figure 10.8

2- Cut the power to the circuit. Open circuit J2 point and short circuit J1 point. In this situation, 100 μ F capacitor is taken out from the circuit and replaced by 1000 μ F capacitor. Apply the power to the circuit. Is there a ripple in the Scope?. If yes, measure approximately. Compare the signal in with this signal.

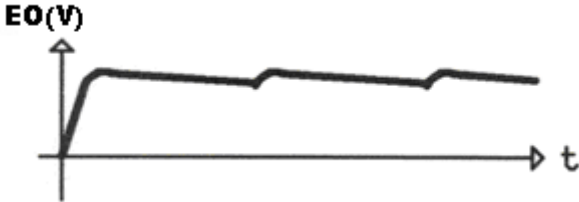

Figure 10.9

3- Based on 1,2 , what is the effect of the capacity value of the capacitor in filtering process?

EXPERIMENT: 2.2

ANALYZING LOAD CURRENT'S EFFECT TO THE FILTER

EXPERIMENT:

Put Y-0016/005 module in place. Connect the circuit shown in Figure 10.10.

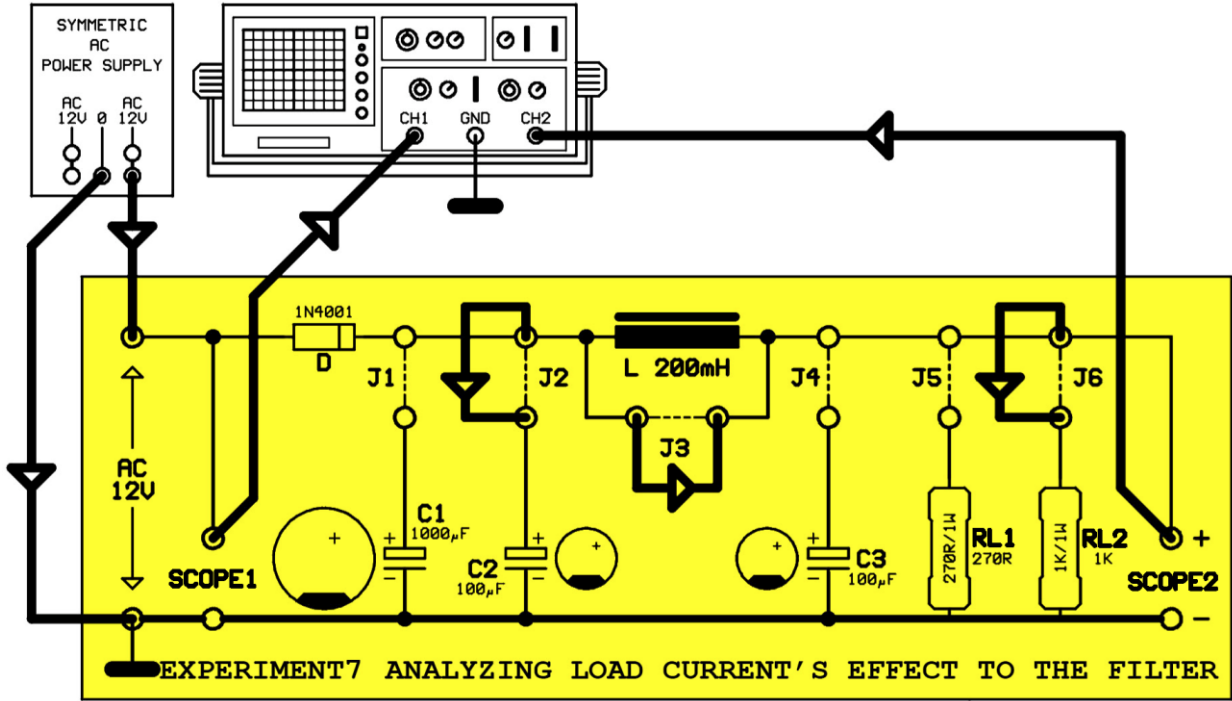

Figure 10.10

Not: J2, J3 and J6 points are short-circuited. At this point, RL2 resistor is circuit load. 100µF electrolytic capacitor is connected parallel to circuit load.

1- Measure the input and output voltages. Considering RL2=1K, Evaluate the circuit current in this case.

$E_i = AC \qquad V_o = DC$ $I = \frac{V_o}{RL2} = \qquad mA$
--

2- Evaluate the ripple voltage (V) considering Circuit current is 15mA, input frequency f=50Hz and filter capacitor 100μF.

$$V = 200 \cdot \frac{I}{f \cdot C}$$

V =

3- Cut the power to the circuit. Open the J6 jumper and short circuit J5 jumper. At this situation, the circuit load is resistor RL1, which is 270R. Measure the input and output voltages by using a multimeter and not fiddling with the circuit. Evaluate the circuit current.

Ei=AC

Vo=DC

$$I = \frac{V_o}{RL1} =$$

4- Evaluate the ripple voltage in this case.

$$V = 200 \cdot \frac{I}{f \cdot C}$$

V =

5- Explain the relation between the circuit current and ripple voltage by considering the results of 3. and 4. . Explain the reason of increasing ripple voltage.

2- Open the J3 jumper. Observe the change in output signal at this point and explain.

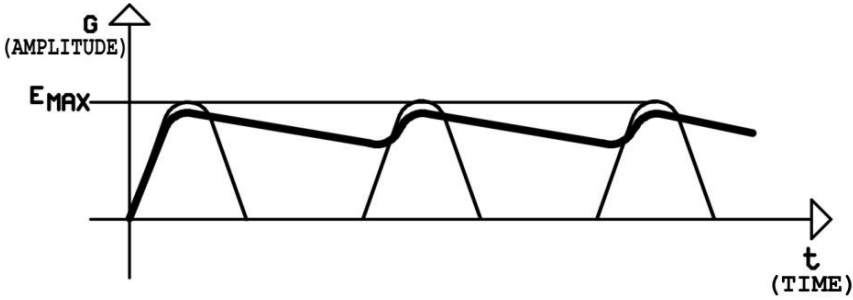

Figure 10.13

EXPERIMENT: 2.4 EXAMINATION OF VOLTAGE DOUBLER

EXPERIMENTAL PROCEDURE:

Plug the Y-0016/006 module. Make the circuit connections as in figure 11.2

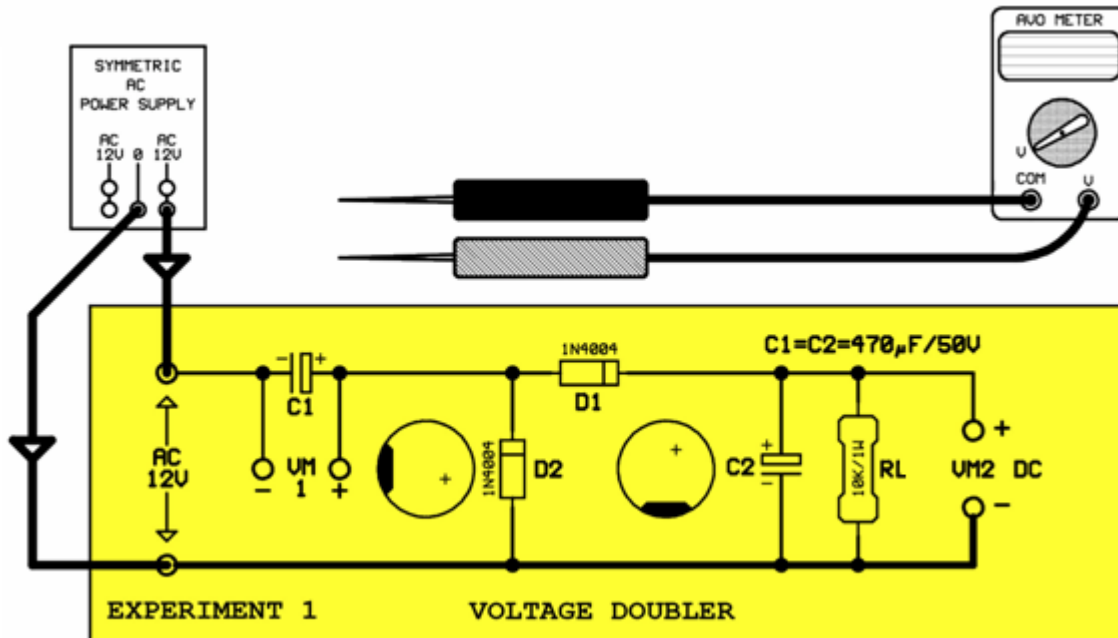

Figure 11.2

1-Apply power to circuit. Measure the alternating input voltage (E_i), voltage on the terminals of C1 ($VM1$) and output voltage (V_o).

$$E_i = AC$$

$$VM1 = DC$$

$$VM2 = V_o = DC$$

2-Calculate the maximum value of alternating voltage that has an effective value of 12,6Volt

$$E_{MAX} = 1,41.E_i =$$

3-What is the relation between the voltages on terminals of C1 and C2 capacitors?

EXPERIMENT: 2.5

EXAMINATION OF VOLTAGE TRIPPLER

EXPERIMENTAL PROCEDURE:

Plug the Y-0016/006 module. Make the circuit connections as in figure 11.4

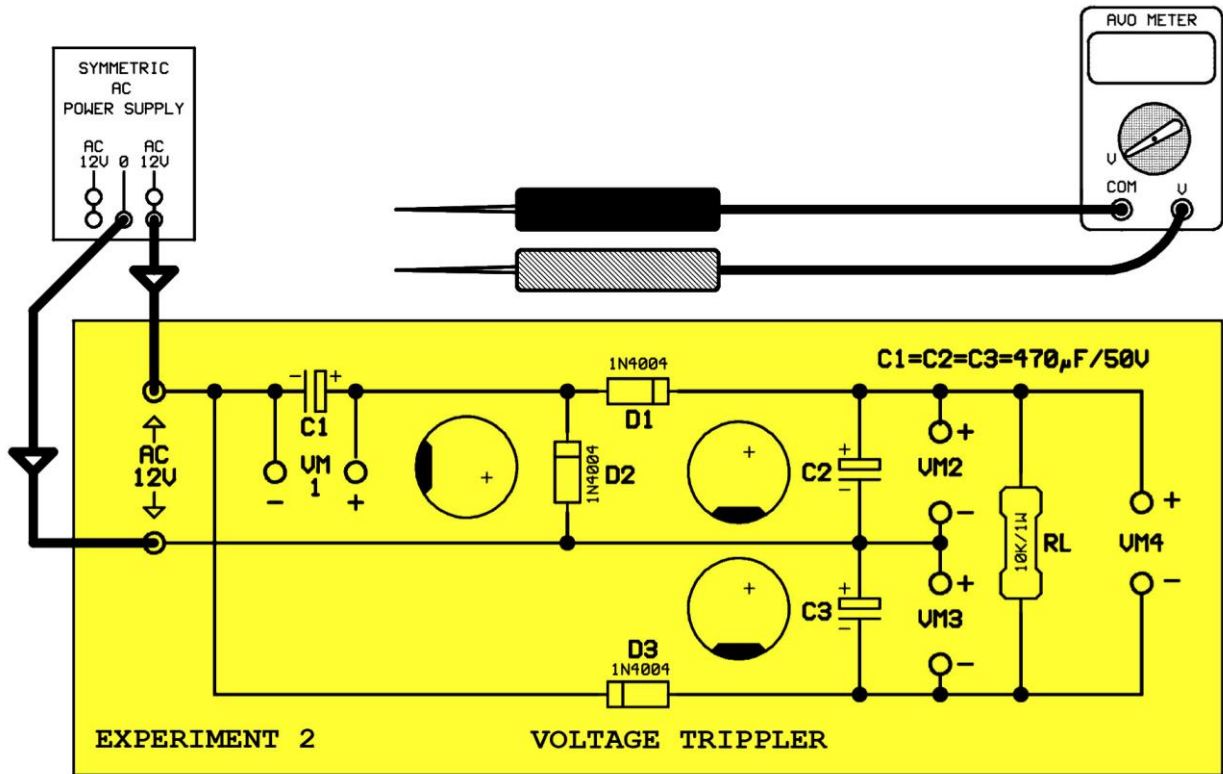

Figure 11.4

1-Apply power to the circuit. Measure the alternating input voltage (E_i), voltage on the terminals of each capacitor and output voltage (V_o)

$E_i = AC$
 $VM1 = DC$
 $VM2 = DC$
 $VM3 = DC$
 $V_o = DC$

2- Does the circuit work as voltage tripler?

EXPERIMENT: 2.6

EXAMINATION OF VOLTAGE QUADRUPLER

EXPERIMENTAL PROCEDURE:

Plug the Y-0016/006 module. Make the circuit connections as in figure 11.6

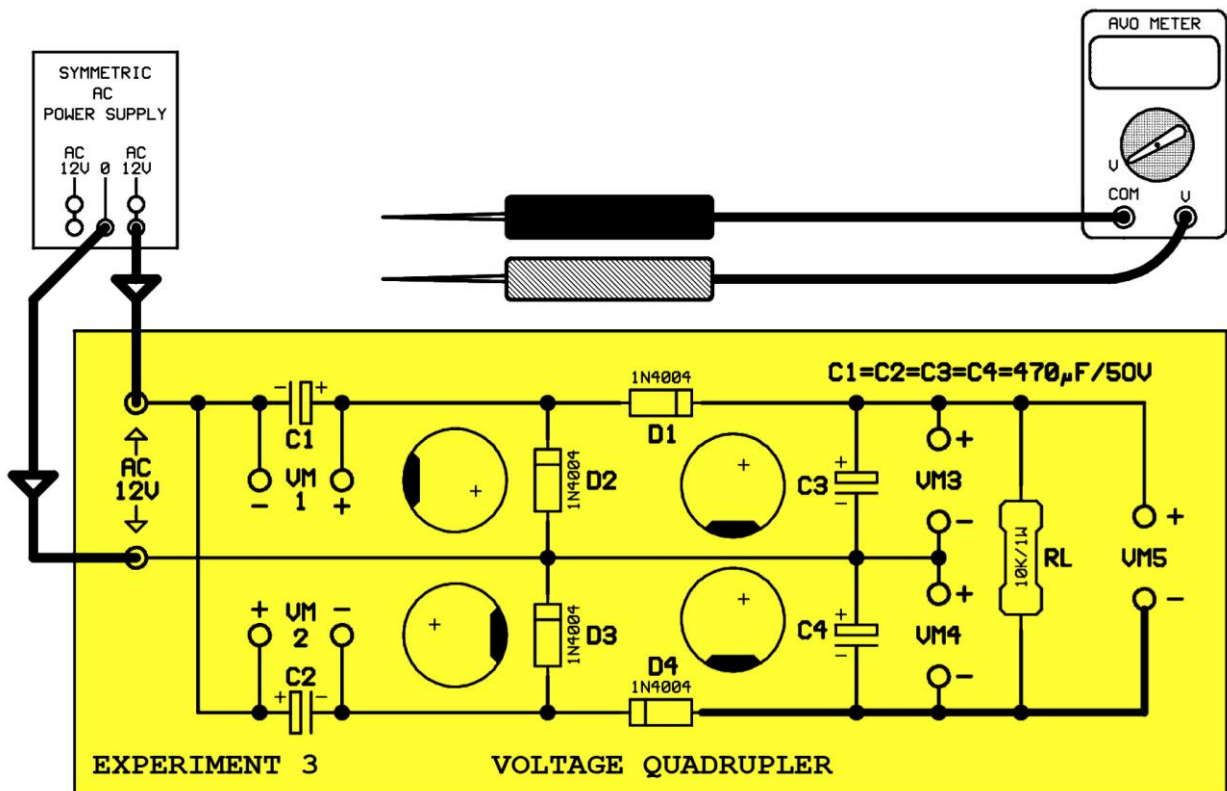

Figure 11.6

1-Apply power to the circuit. Measure the alternating input voltage (E_i), voltage on the terminals of each capacitor and output voltage (V_o)

$E_i = AC$
 $VM1 = DC$
 $VM2 = DC$
 $VM3 = DC$
 $VM4 = DC$
 $V_o = DC$

2- Does the circuit work as voltage quadrupler?