

ELECTRONICS LAB.

PART 2

Yrd. Doç. Dr. Taha İMECİ

Arş. Gör. Ezgi YAMAÇ

Arş. Gör. Ufuk ŞANVER

İSTANBUL COMMERCE UNIVERSITY

Contents

<i>FILTER CIRCUITS</i>	2
3.1 INTRODUCTION	2
3.2 CAPACITOR AND COIL IN FILTER CIRCUITS	2
<i>VOLTAGE MULTIPLIERS</i>	7
4.1 INTRODUCTION	7
4.2 VOLTAGE DOUBLER	7
4.3 VOLTAGE TRIPPLER	8
4.4 VOLTAGE QUADRUPLER.....	9

FILTER CIRCUITS

3.1 INTRODUCTION

As shown in full and half wave rectifier experiments, the outputs of the rectifiers are not constant steady DC voltages. Electronic equipments can not work with this type of voltage sources because of the short segments of zero voltage. Filter circuits are used in order to eliminate this problem. Huge capacity capacitors or coils with high inductance values are used in filter circuits.

3.2 CAPACITOR AND COIL IN FILTER CIRCUITS

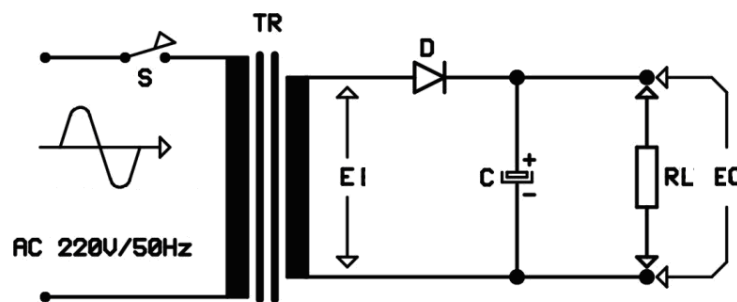

Figure 3. 1

A half wave rectifier with an electrolytic capacitor connected parallel to the load is shown in Figure 3.1. The capacitor stores electrical energy when the voltage across its pins increases. This event is called "charging". A charged capacitor applies its stored energy on the load if the voltage across the pins decreases. This event is called "discharging" of the capacitor. The charging time of the capacitor depends on the capacitance value of it and it is directly proportional to the capacity. The discharging time of the capacitor is related to the resistance value of the circuit load and is directly proportional to the resistance value. If the capacitor is charged with no circuit load, the stored electrical energy remains for a very long time after the circuit power is gone. If two pins of the high-capacity capacitor is touched at the same time, an electrical shock happens. For this reason, the capacitor must be connected parallel to a resistor and it must be discharged after the circuit power is cut. This resistor value is chosen such that it may pass $1/10^{\text{th}}$ of the maximum load current, and its maximum power must also be selected carefully. This resistor also provides a balanced charging of the capacitor. In circuits in which the load is always in the circuit, this resistor is not needed. If the output signal is analyzed with an oscilloscope, A figure similar to Figure 3.2 can be observed.

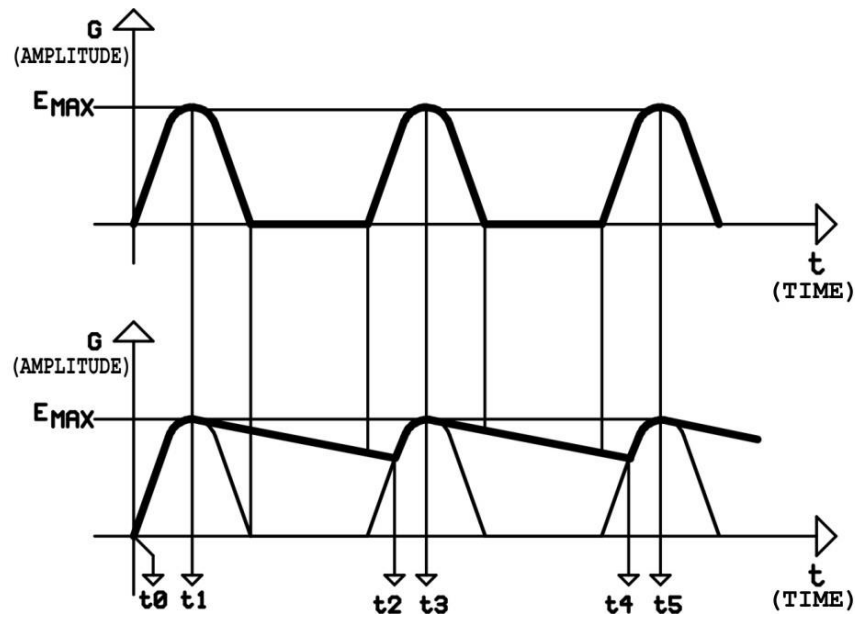

Figure 3. 2

The signal on top is the signal when there is no capacitor. The effect of capacitor to the output signal is shown in the below subfigure. The capacitor, because it is directly connected to the diode output, starts a fast charging in time interval "t0-t1". At point t1, it is charged with maximum voltage. For this reason, the working voltage of the capacitor must be at least the maximum voltage value. The charging time is approximately one fourth of the period time. Considering the city electricity network has a frequency of 50 Hz, the charging time can be evaluated by first finding the period;

$$T = \frac{1}{f} = \frac{1}{50} = 0,02\text{sec} = 20\text{msec}$$

$$\text{Charging time} = \frac{T}{4} = \frac{20}{4} = 5\text{msec}$$

After "t1" point, the voltage on the capacitor pins starts to decrease. At this moment, capacitor starts to discharge over the load for fixating the voltage on the load pins. The discharging time of the capacitor depends on capacity value of it and the resistance of the resistor. Time interval of discharge is called "time constant" and has the following formula:

$$T=R.C$$

in which

T= Time Constant (Seconds)

R= Load resistance (Ohm)

C= Capacity (Farad).

As an example, if capacitor value is $C=1000\mu\text{F}$ and load resistance value is $R=1\text{K}$, time constant is;

$$T=R.C$$

$$T=1000.1000.10^{-6}=1\text{seconds.}$$

The discharging of the capacitor takes a long time. When discharging continues, the second positive alternation charges the capacitor again. t_1-t_2 period is the time capacitor is discharging, t_2-t_3 period is the second time charging period. The capacitor discharges again in t_3-t_4 time period. This cycle repeats in operation period. Bu olay çalışma zamanı boyunca devam eder.

Capacitor smoothed the segmented direct voltage and shaped it to direct voltage with waves. This waving is called "ripple". The whole process to smoothing the amplitude and obtain a steadier voltage is called "filtering" or "regulating". The filter gets better if the capacity of the capacitor is increased. In practice, capacitors with capacity in between $1000\mu\text{F}$ - $10000\mu\text{F}$ are used. The acceptable ripple voltage is 100mV . For the electrical signals to be observed better, the capacity values in the experiment module is selected from slow values

The conducting times of the diode is only when the capacitor is charging. In the discharging times, the diode is not conducting since it is in reverse bias. The breakdown voltage (E_k) in the reverse bias of the diode must be at least $E_k=2,82.E$. The diode current is shown in Figure 3.3.

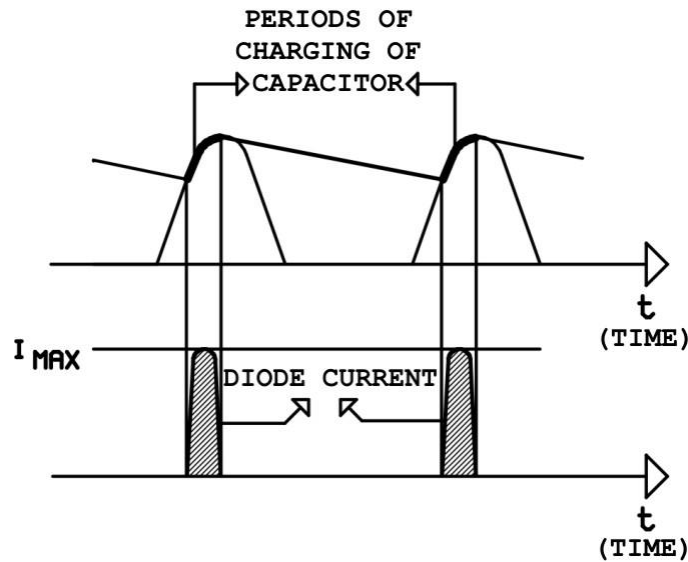

Figure 3. 3

The shape of the current passing over the diode in one alternation is called "pulse". Considering the city network frequency of 50Hz , half wave and full wave rectifiers have 50 and 100 pulses in one period, respectively. dalga doğrultmaçlarda 100pals geçer. The currents passing as pulses during working period may produce unwanted noise in the electronic devices. For this reason, a capacitor connected paralel to the diode can eliminate this noise. The value of the capacitor that is to be connected parallel is in the range between 47nF - 220nF .

Ripple voltage (V) can be evaluated by;

$$V = 200 \cdot \frac{I}{f \cdot C}$$

In which;

- V= Ripple voltage (Volt)
- I= Circuit current (mA)
- F= Frequency of the input signal (Hz)
- C= Capacity (μF)

As the formula implies, the ripple voltage is directly proportional with the circuit current.

Filtering process in full wave rectifiers are simpler, due to the fact that output signal is present in all alternations. The filtering done by capacitor in full wave rectifiers are shown in Figure 3.4.

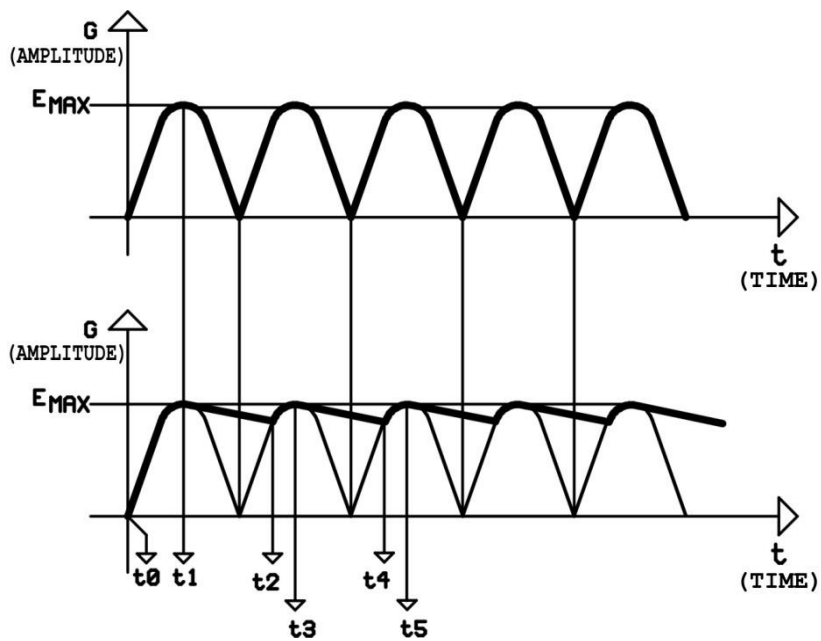

Figure 3. 4

Capacitors are the most crucial components of the filters. Coils also behave in the other way with the change of the current flow, therefore used in the filtering circuits. The coils used in filter circuits are called "choke coils". Coils are connected in series with the circuit load, and smooth the signals especially when the signal has instantaneous change. An example to the instantaneous change points are charging of the capacitor with the increasing side of the alternation when the capacitor is discharging and the peak points of the alternations. The output signal of the filter circuit in which capacitor and coil is used is shown in Figure 3.5.

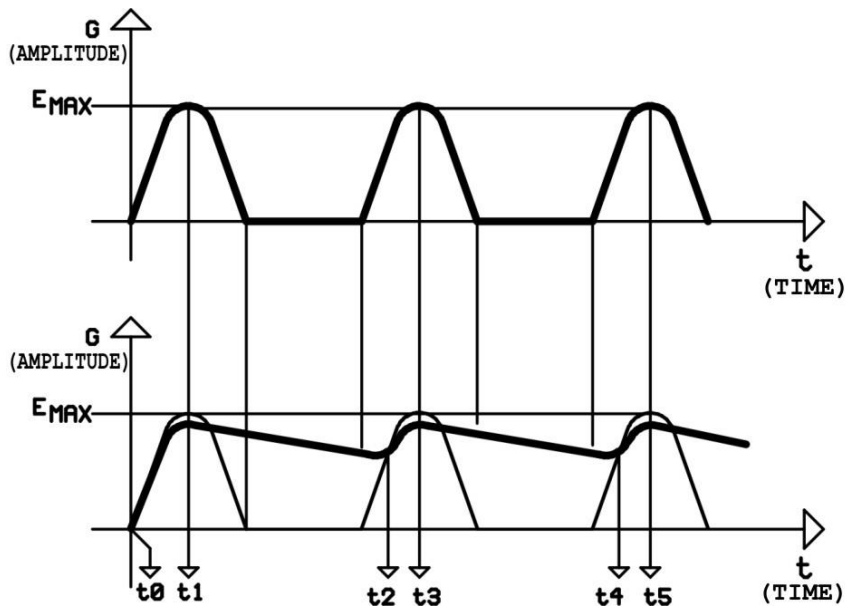

Figure 3. 5

There is a small amount of voltage loss due to the ohmic resistances of the coils. This is an unwanted situation, which results in a small amount of energy loss. In practical filter circuits, coils with iron cores in the order of 5H-100H are used. The physical size of the coil increases with the increase in the inductance and wire diameter. The coil to be used must have the wire diameter that can carry the circuit current. A low inductance coil is used in the circuit module due to space problems. The coil is placed into the module. The coil and capacitor can be connected in different ways in filter circuits. The most frequently used connection type is "π type" connection, which is shown in Figure 3.6. Very good filters can be produced with this connection.

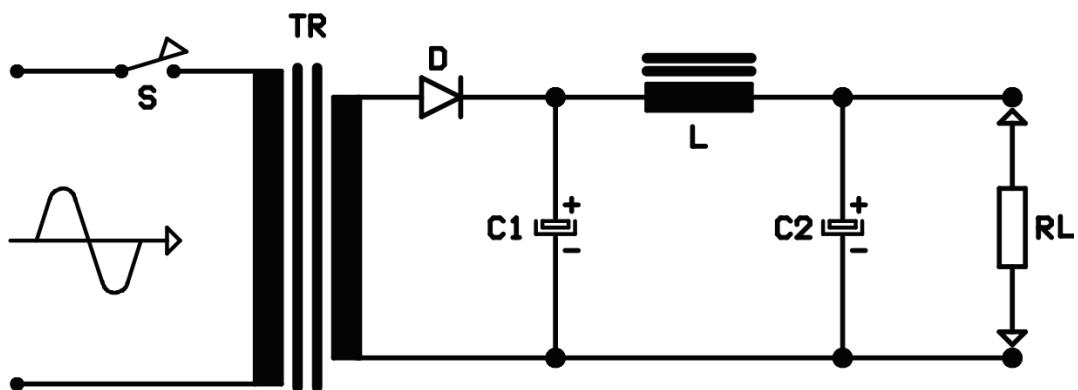

Figure 3. 6

VOLTAGE MULTIPLIERS

4.1 INTRODUCTION

Voltage multipliers simply develop high voltages as output from low voltages of input. They are used in feeding the low current circuits. The most commonly used voltage multipliers are voltage doublers, triplers and quadruplers.

4.2 VOLTAGE DOUBLER

Voltage doublers generate the double of voltage applied as input. They consist of two diodes and two capacitors. Below circuit is an example of voltage doubler.

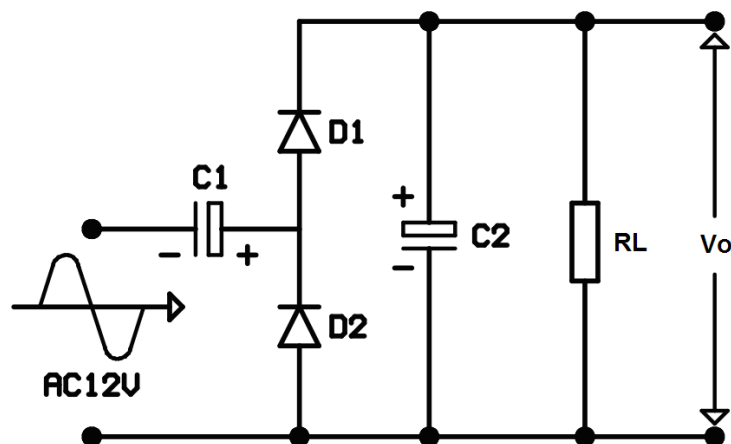

Figure 4. 1

At the negative alternation of alternating voltage, D2 diode starts transmission and C1 capacitor starts to charge at bias seen at figure 4.1

Voltage on the terminals of C1 capacitor draws very close to the maximum value of alternating input voltage. Maximum value is 1,41 times the effective value. At the positive alternation of alternating voltage, anode of D1 diode takes the required positive bias both from input alternating voltage and from the charge of C1 and D1 diode becomes conductor. At that moment D2 diode is non- conductor. As a result of transmission of D1 diode, C2 capacitor is charged as much as the sum of voltage on C1 and maximum positive value of alternating voltage. Therefore, there will be generated a voltage equal to the double of the maximum value of input alternating voltage. In other words, a DC output (on the terminals of RL resistor) is generated which has a value equal to the peak to peak value alternating voltage. Voltage doubler needs to be filter in order to make the output voltage available for use. The filter circuit used in other rectifiers can be used for filtering the doubler.

Working voltage of C2 electrolytic capacitor should be the double of working voltage of C1.

4.3 VOLTAGE TRIPPLER

Voltage triplers are circuits developed through appropriate combination of the half wave rectifier and voltage doubler. An example of tripler can be seen in figure 4.2

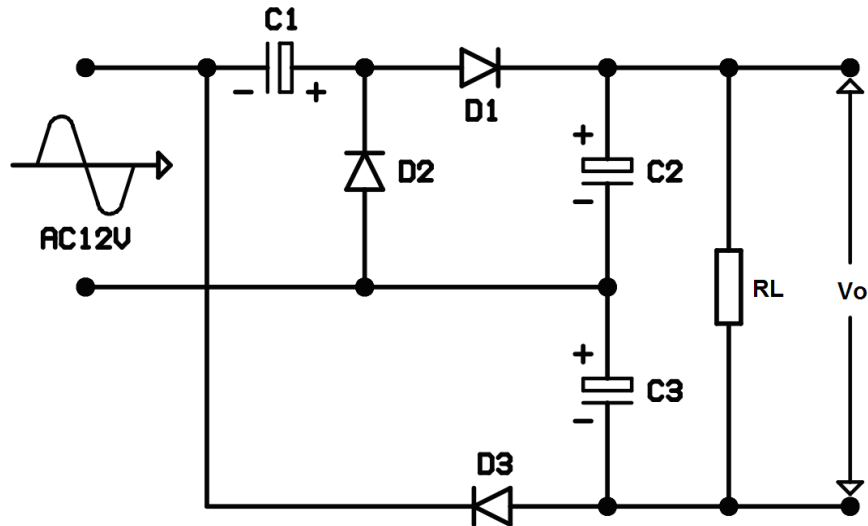

Figure 4. 2

When the lower terminal of alternating voltage is positive and upper terminal is negative, D2 diode charges C1 capacitor and D3 charges C3. In the alternation when the upper terminal is positive and the lower terminal is negative, D1 starts transmission. C2 charges to the double of input voltage as a result of discharging of C1 and addition of its charge to positive alternation. Therefore, voltages on C2 and C3 are combined as seen in figure 4.2

As a result, tripple of the maximum value of alternating input voltage is generated as output.

4.4 VOLTAGE QUADRUPLER

Voltage quadrupler is developed by combining two voltage doubler; their inputs are connected serially and outputs are connected parallelly. One of the doublers consists of D1, D2, and C1, C2 components; the other one consists of D3, D4 and C3, C4 components. An example of quadrupler can be seen in figure 4.3

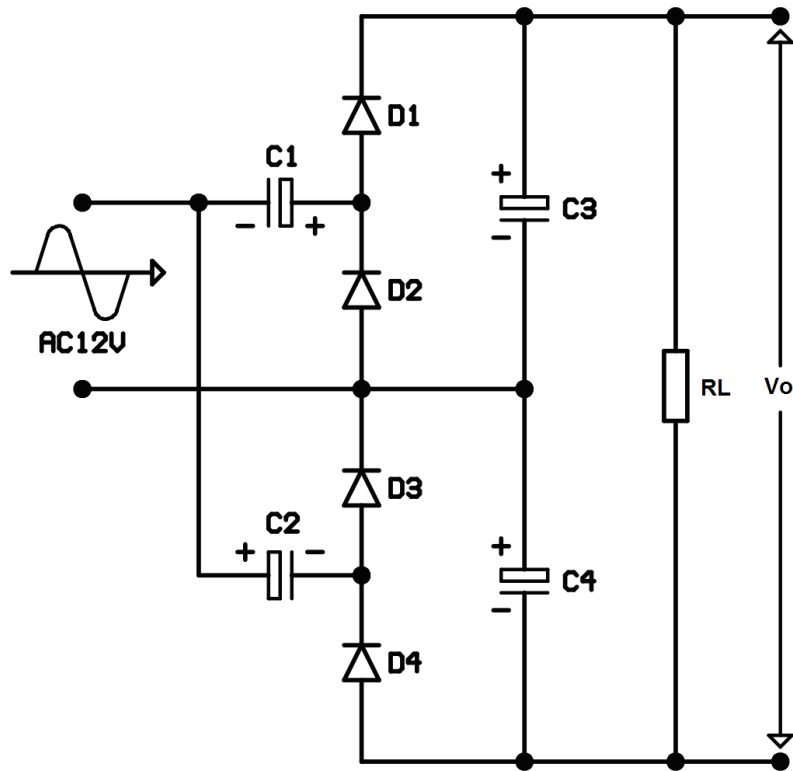

Figure 4. 3

When the upper terminal of input is negative and lower terminal is positive, D2 and D4 diodes become conductors. Current of D2 diode charges C1 capacitor. Discharge current of C2 and D4 diode charges C1 capacitor. When the lower terminal of input is negative and upper terminal is positive, D1 diode and the charge of C1 charges C3 and D3 diode charges C2.

So, the output discharge voltage of C3 and C4 are the double of input voltage. They are equal voltages and serial connected at the RL terminals. So, output voltage on the terminals of RL is the quadruple of input voltage ($4 \times 1,41 = 5,64$). These voltage multiplier circuits are used in devices requiring high voltage and low current.