

ELECTRONICS LAB.

PART 7 EXPERIMENTS

Yrd. Doç. Dr. Taha İMECİ

Arş. Gör. Ezgi YAMAÇ

Arş. Gör. Ufuk ŞANVER

İSTANBUL COMMERCE UNIVERSITY

Contents

EXPERIMENT 7.1	2
EXAMINATION OF TRANSISTOR SOUND AMPLIFIERS.....	2
EXPERIMENT: 7.2	5
EXAMINATION OF INTEGRATED SOUND AMPLIFIER.....	5
EXPERIMENT 7.3	8
EXAMINATION OF JFET'S INPUT CHARACTERISTICS	8
EXPERIMENT: 7.4	10
EXAMINATION OF JFET'S OUTPUT CHARCTERISTICS	10
EXPERIMENT: 7.5	13
EXAMINATION OF SOURCE GROUND CONNECTION	13

EXPERIMENT 7.1

EXAMINATION OF TRANSISTOR SOUND AMPLIFIERS

EXPERIMENT:

1- Put Y-0016/011 module in place. Connect the circuit shown in Figure 16.13.

NOTE: 8R/2W resistor on the module will be used as speaker

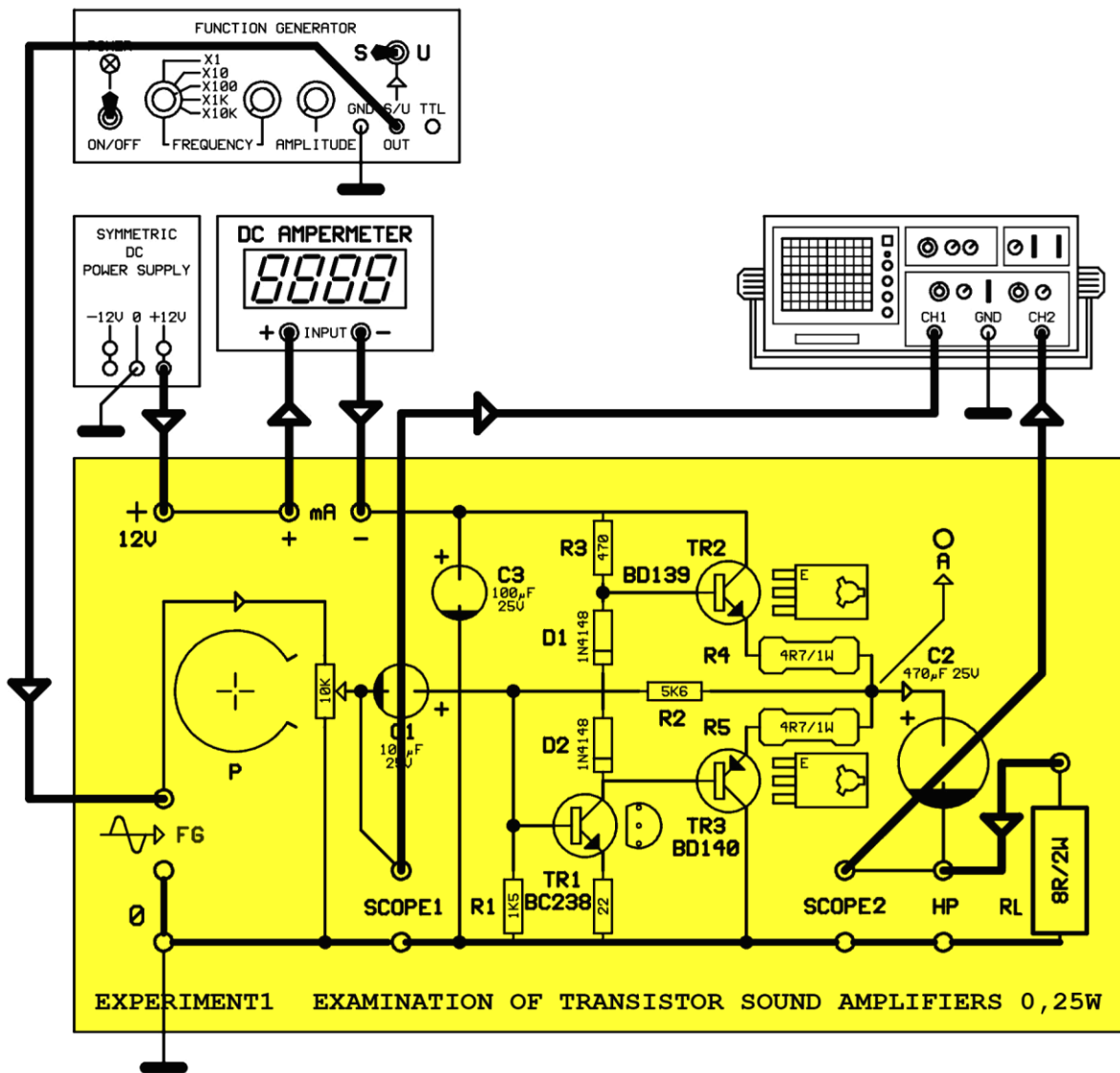

Figure 9.1.4

2- Adjust potentiometer P to maximum condition (**middle pin on top**). Only apply power to the function generator. Adjust the output of function generator to Scop1, sinusoidal signal with frequency 1 KHz and amplitude peak-peak **V_{ipp}=1V** .Adjust potentiometer "P" to minimum condition (**middle pin on bottom**)

3- Power on the sound amplifier. Measure the current drawn by sound amplifier. What is this current's definition and why?

4- Adjust the P potentiometer to obtain maximum distortion-free amplitude at Scop2. Measure the current drawn by sound amplifier. What is this current and why? Evaluate the value in terms of efficiency.

5- Measure the input and output signal amplitude when the output signal have distortion-free maximum amplitude value. Evaluate the voltage gain of the sound amplifier.

Input signal peak-peak **V_{ipp}**=.....Volt.
 Output signal peak-peak **V_{opp}**=.....Volt.
 Voltage gain (**A**);

$$A = 20Lg. \frac{V_o}{V_i} =$$

$$A =dB$$

6- Evaluate the output power of the sound amplifier (**P**).

Output signal peak-peak **V_{opp}**=.....Volt.
 Maximum output voltage

$$E_{max} = \frac{V_{opp}}{2} =Volt$$

Effective output voltage (**E**);

$$E = E_{max} \cdot 0,707 =Volt$$

Output power (**P**);

$$P = \frac{E^2}{Z} =Watt$$

NOT: Z is the speaker impedance, where we used RY load resistance in the circuit, which is RL=8Ω.

7-For the values in table of Figure 16.14 measure and note output voltage (**V_{opp}**) for all steps.

V _{i_{pp}} =500mV CONSTANT			V _{i_{pp}} =500mV CONSTANT		
NUMBER	FREQUENCY	V _{o_{pp}} (V)	NUMBER	FREQUENCY	V _{o_{pp}} (V)
1	20 Hz		7	3 KHz	
2	50 Hz		8	4 KHz	
3	100 Hz		9	5 KHz	
4	500 Hz		10	10 KHz	
5	1 KHz		11	15 KHz	
6	2 KHz		12	20 KHz	

Figure 16.14

8- Based on your measurements in Figure 16.14, plot the frequency characteristic of the sound amplifier using the output voltage values.

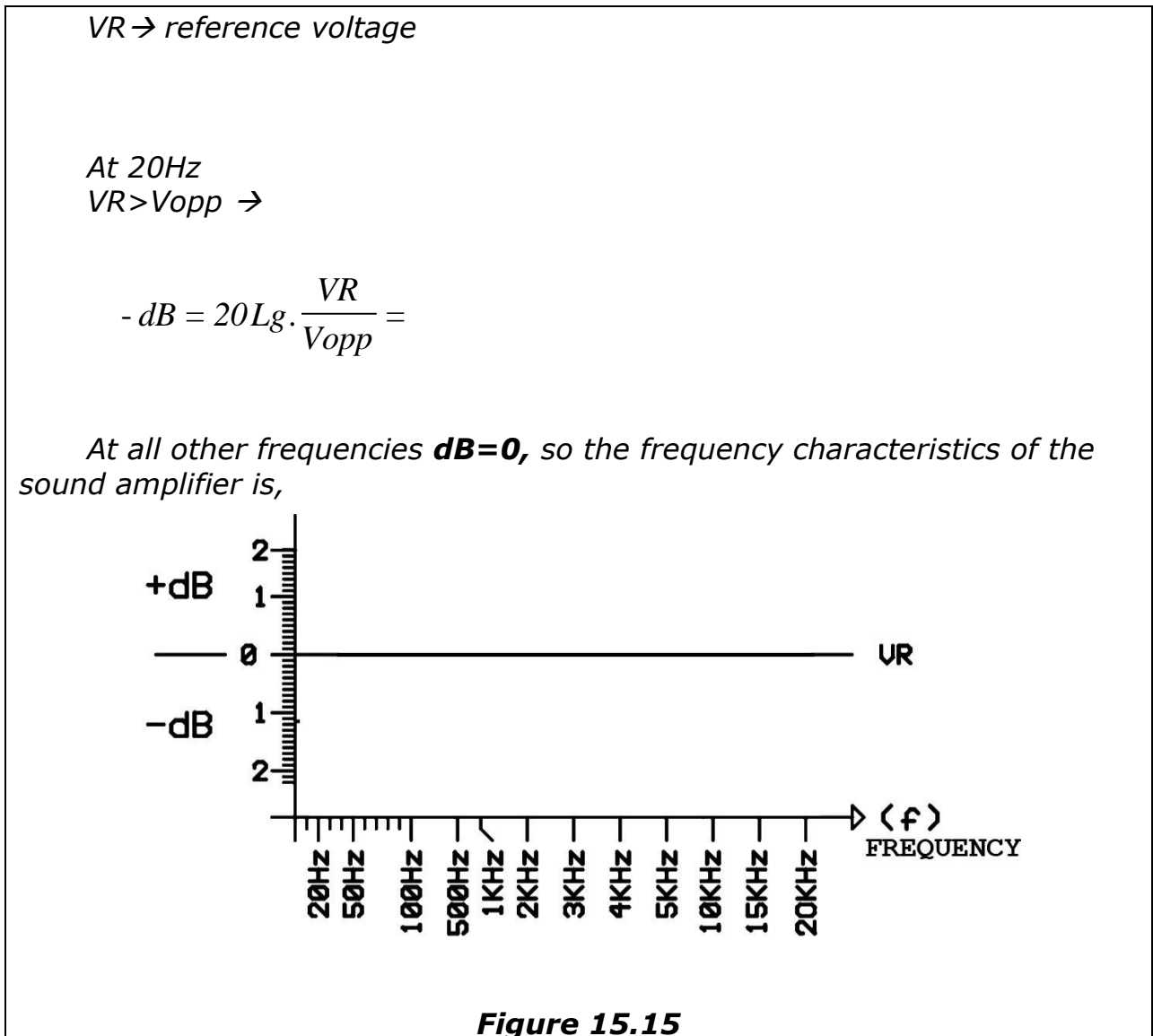

Figure 15.15

EXPERIMENT: 7.2

EXAMINATION OF INTEGRATED SOUND AMPLIFIER

EXPERIMENT:

1- Put the Y-0016/011 module in place. Connect the circuit as shown in Figure 16.18.

NOTE: 8R/2W resistor on the module will be used as speaker.

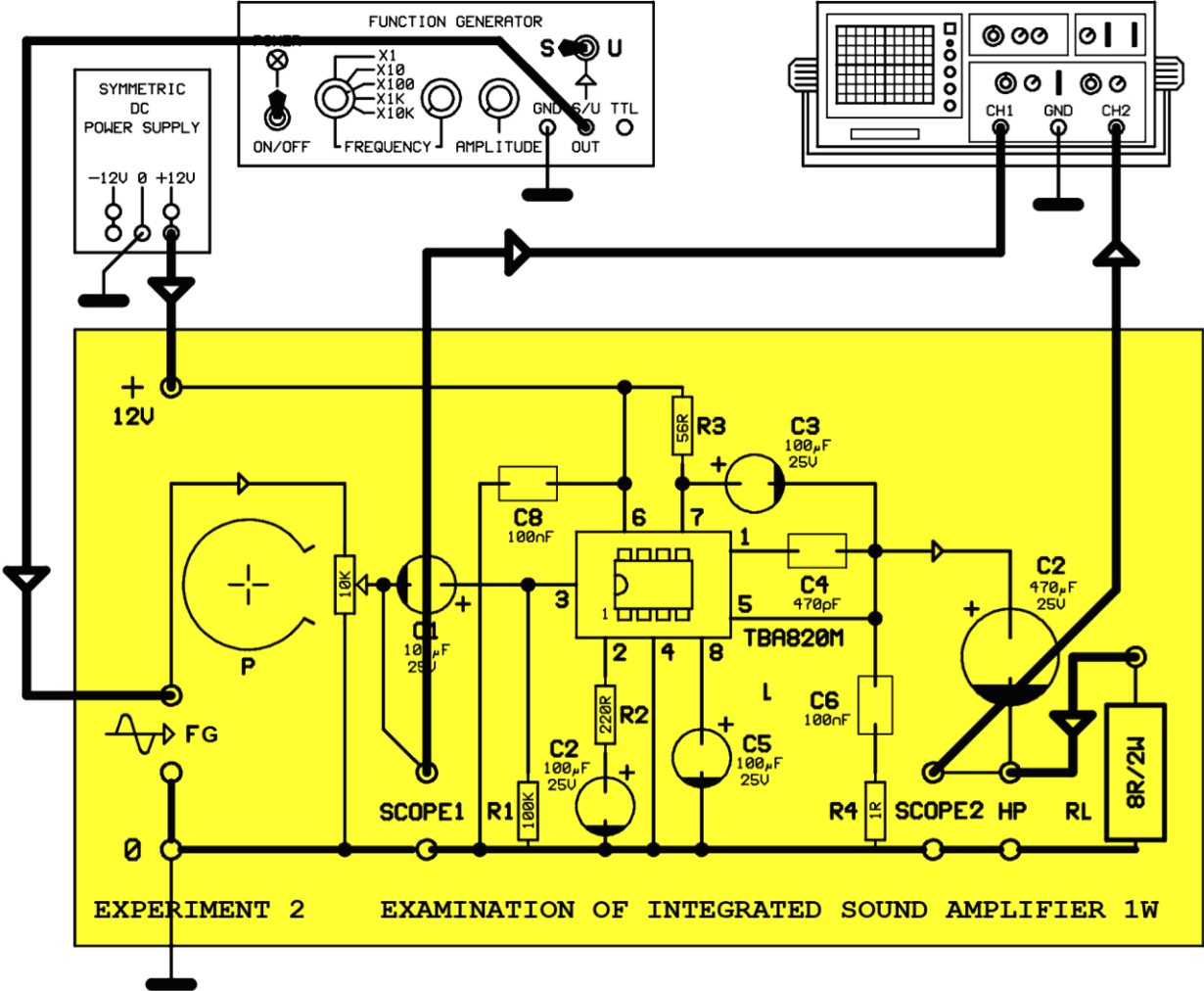

Figure 16.18

2- Adjust the "P" potentiometer to the maximum value (**middle pin on top**). Only power the function generator. Adjust the signal of the function generator to a 1Khz frequency **V_{ipp}** = 1Volt peak-to-peak sinusoidal at Scope1. Adjust the "P" potentiometer to the minimum value (**middle pin on bottom**).

3- Power the sound amplifier. Adjust the P potentiometer and obtain maximum amplitude and no distortion at Scope2. Measure the input and output signal amplitudes when the output signal is at maximum amplitude and no distortion. Calculate the voltage gain of the sound amplifier.

Input signal voltage peak to peak is **VIpp**=.....Volt
 Output signal voltage peak to peak is **VOpp**=.....Volt.

Voltage Gain (**A**);

$$A = 20Lg. \frac{V_o}{V_i} =$$

A=.....dB

4- Calculate the output power of the sound amplifier. (**P**)

Output signal voltage peak to peak is **VOpp**=.....Volt.
 Maximum output voltage (**E_{max}**);

$$E_{max} = \frac{V_{opp}}{2} = \dots\dots\dots Volt$$

Effective output voltage (**E**);
 E=E_{max} x 0.707=.....Volt
 Output power(**P**);

$$P = \frac{E^2}{Z} = \dots\dots\dots Watt$$

5- Measure the output voltage (**VOpp**) based on the values in tables of Figure 16.19.

Vi _{pp} =250mV CONSTANT			Vi _{pp} =250mV CONSTANT		
NUMBER	FREQUENCY	Vo _{pp} (V)	NUMBER	FREQUENCY	Vo _{pp} (V)
1	20 Hz		7	3 KHz	
2	50 Hz		8	4 KHz	
3	100 Hz		9	5 KHz	
4	500 Hz		10	10 KHz	
5	1 KHz		11	15 KHz	
6	2 KHz		12	20 KHz	

Figure 16.19

6- Using the output voltages in Figure 16.19, plot the frequency characteristics of the sound amplifier between the frequency-decibel axes.

Based on the values, the reference voltage (V_R) is.....Volts. dB sign is negative since at each step $V_R > V_{opp}$

$$\text{For : } 20\text{Hz} \rightarrow \text{dB} = 20.Lg.\frac{V_R}{V_{opp}} =$$

$$\text{For: } 50\text{Hz} \rightarrow \text{dB} = 20.Lg.\frac{V_R}{V_{opp}} =$$

$$\text{For: } 100\text{Hz} \rightarrow \text{dB} = 20.Lg.\frac{V_R}{V_{opp}} =$$

$$\text{For: } 5\text{KHz} \rightarrow \text{dB} = 20.Lg.\frac{V_R}{V_{opp}} =$$

$$\text{For: } 10\text{KHz} \rightarrow \text{dB} = 20.Lg.\frac{V_R}{V_{opp}} =$$

$$\text{For: } 15\text{KHz} \rightarrow \text{dB} = 20.Lg.\frac{V_R}{V_{opp}} =$$

$$\text{For: } 20\text{KHz} \rightarrow \text{dB} = 20.Lg.\frac{V_R}{V_{opp}} =$$

The frequency characteristics,

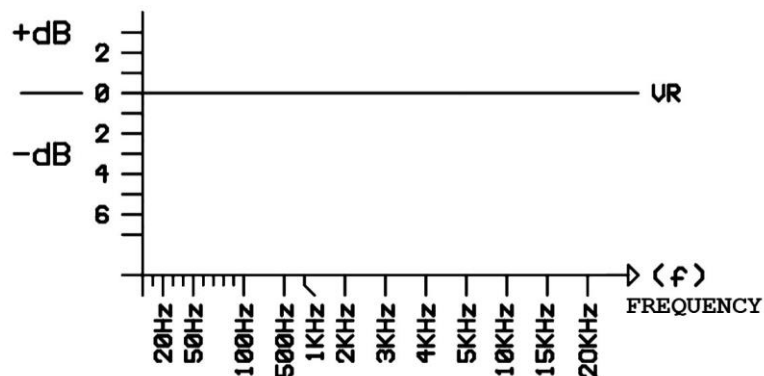

Figure 16.20

EXPERIMENT 7.3

EXAMINATION OF JFET'S INPUT CHARACTERISTICS

EXPERIMENTAL PROCEDURE:

Plug the Y-0016/012 module. Make the circuit connections as in figure 17.5

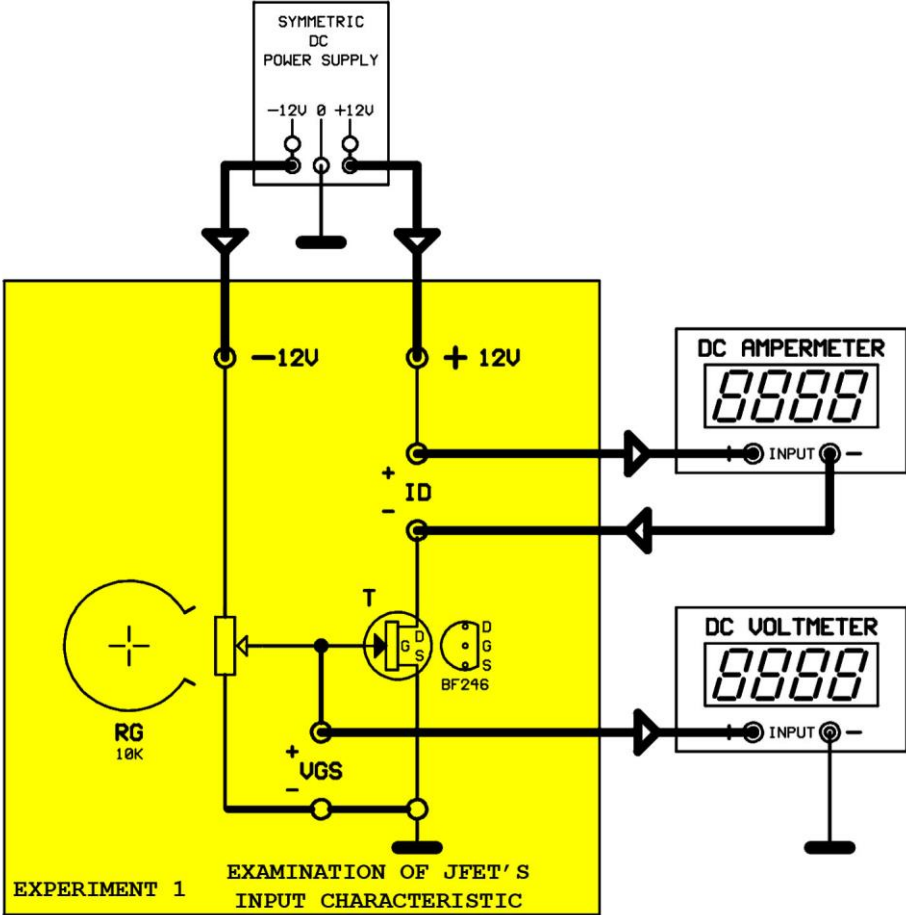

Figure 17.5

1- Type the VGS voltage to the table at figure 17.6 with the help of RG potentiometer. Also type the ID values for each step.

$V_{DS}=12V$ CONSTANT	
V_{GS} (VOLT)	I_D (mA)
0.0	
-0.5	
-1.0	
-1.5	
-2.0	
-2.5	
-3.0	
-3.5	
-4.0	

Figure 17.6

2- Draw the V_{GS}/I_D curve using the values in figure 17.6

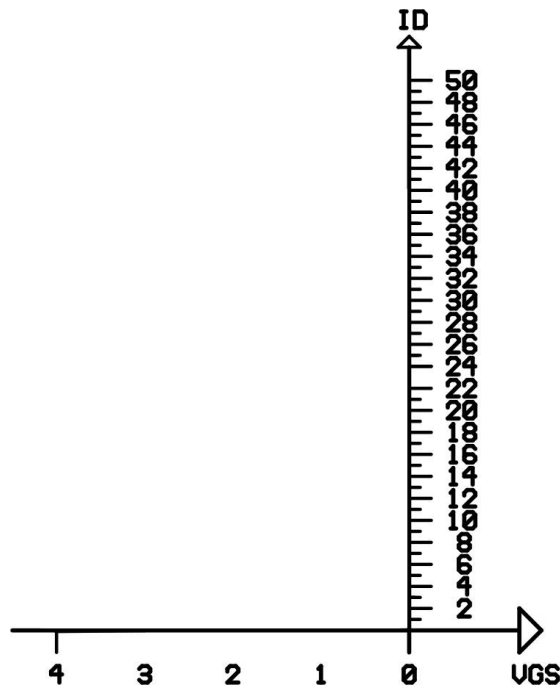

Figure 17.7

3- When the $V_{GS}=-3.5V$ or at a smaller value $I_D="0"$. What is the name for this value of V_{GS} ?

EXPERIMENT: 7.4

EXAMINATION OF JFET'S OUTPUT CHARACTERISTICS

EXPERIMENTAL PROCEDURE:

Plug the Y-0016/012 module. Before making the connections, adjust the output voltage of power supply to "0" by rotating voltage potentiometers to left. And adjust the gate voltage to "0" by rotating the "RG" potentiometer to left.

Make the circuit connections as in figure 17.10 and apply energy to circuit.

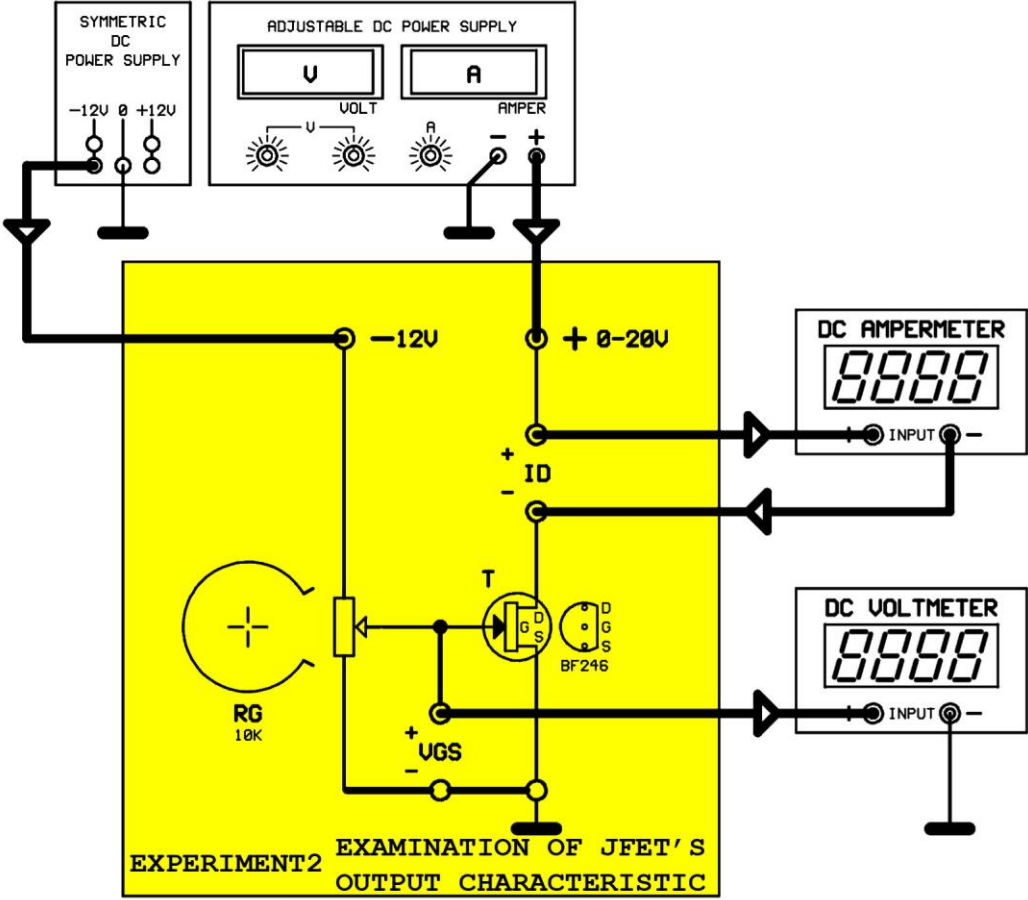

Figure 17.10

1-Set $V_{GS}=0$ using "RG" potentiometer. Adjust the power supply voltage to the V_{DS} voltage values in figure 17.11 and make sure that $V_{GS}=0$ at each step. Type the I_D values at each step to section "A".

VGS=0 CONSTANT		VGS=-1 CONSTANT		VGS=-2 CONSTANT		VGS=-3 CONSTANT		VGS=-4 CONSTANT	
VDS (VOLT)	ID (mA)	VDS (VOLT)	ID (mA)	VDS (VOLT)	ID (mA)	VDS (VOLT)	ID (mA)	VDS (VOLT)	ID (mA)
1		1		1		1		1	
2		2		2		2		2	
3		3		3		3		3	
4		4		4		4		4	
5		5		5		5		5	
10		10		10		10		10	
15		15		15		15		15	
20		20		20		20		20	

— A —
— B —
— C —
— D —
— E —

Figure 17.11

2- Draw the change graphic between VDS/ID axes like in figure 17.12

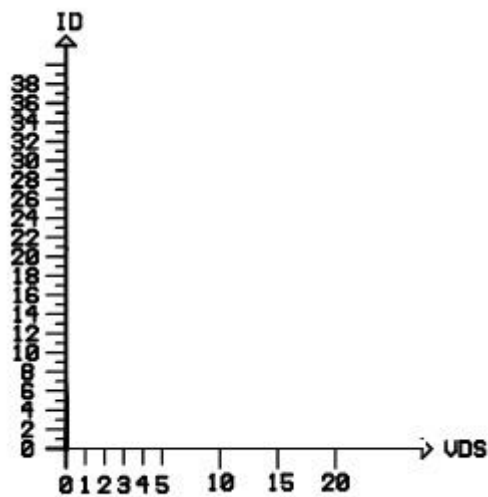

Figure 17.12

3- ID is constant even if the VDS is increased. What is the name for this value of ID?

4- Adjust the VGS voltage to -1V, -2V, -3V, -4V, respectively. Adjust the VDS voltage to the values in figure 17.13 and type each ID value next to each VDS value.

VGS=0 CONSTANT		VGS=-1 CONSTANT		VGS=-2 CONSTANT		VGS=-3 CONSTANT		VGS=-4 CONSTANT	
VDS (VOLT)	ID (mA)	VDS (VOLT)	ID (mA)	VDS (VOLT)	ID (mA)	VDS (VOLT)	ID (mA)	VDS (VOLT)	ID (mA)
1		1		1		1		1	
2		2		2		2		2	
3		3		3		3		3	
4		4		4		4		4	
5		5		5		5		5	
10		10		10		10		10	
15		15		15		15		15	
20		20		20		20		20	

— A —
— B —
— C —
— D —
— E —

Figure 17.13

5- Draw change graphics between VDS/ID axes for each VGS voltage value like in figure 17.12

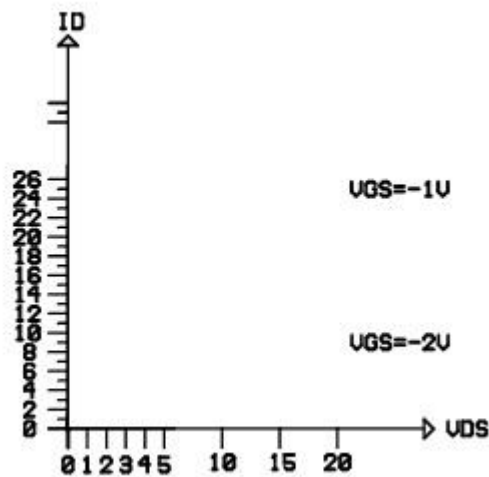

Figure 17.14

6- What is the name for these graphics?

7- Write the effect of gate bias to drain current.

8- Write the effect of VDS voltage to drain current.

EXPERIMENT: 7.5

EXAMINATION OF SOURCE GROUND CONNECTION

EXPERIMENTAL PROCEDURE:

Plug the Y-0016/012 module. Make the circuit connections as in figure 17.18 and apply energy to circuit.

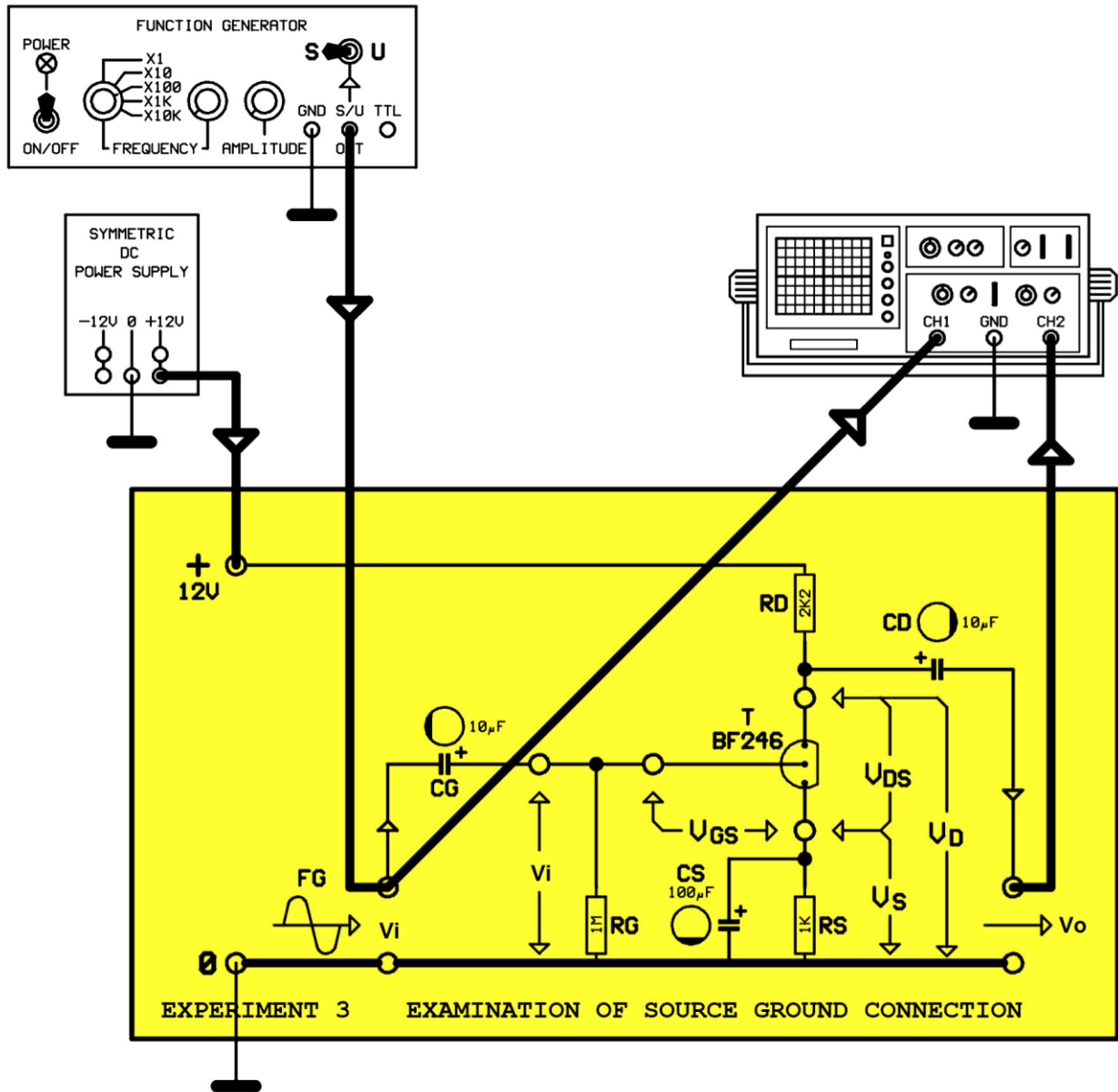

Figure 17.18

1- Disconnect the function generator from the circuit. Measure the V_G , V_{GS} , V_S , V_{DS} , V_D voltages by the help of a digital voltmeter.

V_i	:Volt
V_{GS}	:Volt
V_S	:Volt
V_{DS}	:Volt
V_D	:Volt

2- Adjust the output of function generator to sine, frequency to 1 KHz and peak to peak amplitude to **Vpp**=100mV, and apply to FG input. What is the phase difference of input and output signal? Measure the amplitude of output signal.

.....

Output signal amplitude is Vpp=.....Volt.

3- Calculate the voltage gain of circuit.

Voltage gain:

$$A = \frac{V_{out}}{V_{in}} = \dots\dots\dots$$

4- In which areas the source ground connection is used?