

ELECTRONICS LAB.

PART 7

Yrd. Doç. Dr. Taha İMECİ

Arş. Gör. Ezgi YAMAÇ

Arş. Gör. Ufuk ŞANVER

İSTANBUL COMMERCE UNIVERSITY

Contents

SOUND FREQUENCY AMPLIFIERS.....	2
9.1 INTRODUCTION	2
9.2 MICROPHONES.....	2
9.3 Sound amplifier.....	5
9.4 Speaker	5
9.5 MEASURING THE GAIN IN SOUND AMPLIFIERS	6
9.6 MEASURING THE OUTPUT POWER OF THE SOUND AMPLIFIERS.....	8
9.7 DERIVING FREQUENCY CHARACTERISTICS OF SOUND AMPLIFIERS...	9
9.8 TRANSISTORED SOUND AMPLIFIERS	12
9.9 ANALYSIS OF INTEGRATED SOUND AMPLIFIERS.....	14
FIELD EFFECT TRANSISTORS.....	16
10.1 INTRODUCTION.....	16
10.2 JFET.....	16
10.3 INPUT CHARACTERISTICS OF JFET	18
10.4 OUTPUT CHARACTERISTICS OF JFET	19
10.5 USING JFET AS AMPLIFIER.....	20
10.6 DRAIN GROUND CONNECTION	20
10.7 GATE GROUND CONNECTION	20
10.8 SOURCE GROUND CONNECTION.....	21

SOUND FREQUENCY AMPLIFIERS

9.1 INTRODUCTION

We need to use sound amplifiers for our voices to be heard in big halls or alleys. An amplifying system, made of devices, can be decomposed into three sections.

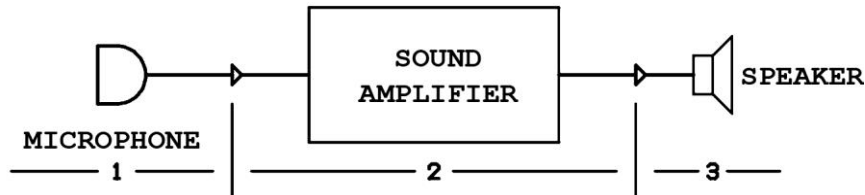

Figure 9. 1

9.2 MICROPHONES

Human voice scatters like the waves produced by a stone thrown into water. The devices that convert sound waves into electrical signals are called "**microphones**". If we analyze the converted electrical signal from the human voice with oscilloscope, we observe that the signal shape is a sinus signal, and the frequency content is in between **20Hz - 20KHz** band. From this, we can conclude that human voice is indeed a sinusoidal signal in the band **20Hz - 20KHz** and the human ear also senses and processes this signal.

6 notable microphone types are produced throughout the history. These are listed below.

- 1-** Carbon microphones
- 2-** Crystal microphones
- 3-** Strip microphones
- 4-** Dynamic microphones
- 5-** Capacitive microphone
- 6-** Electret microphones

The most preferred and used microphone types are dynamic microphones and capacitive microphones.

Dynamic microphone: Dynamic microphones consist of a coil that is placed in a magnetic field produced by a stationary magnet and able to move within sound waves. Cross-section of a dynamic microphone is shown in Figure 9. 2.

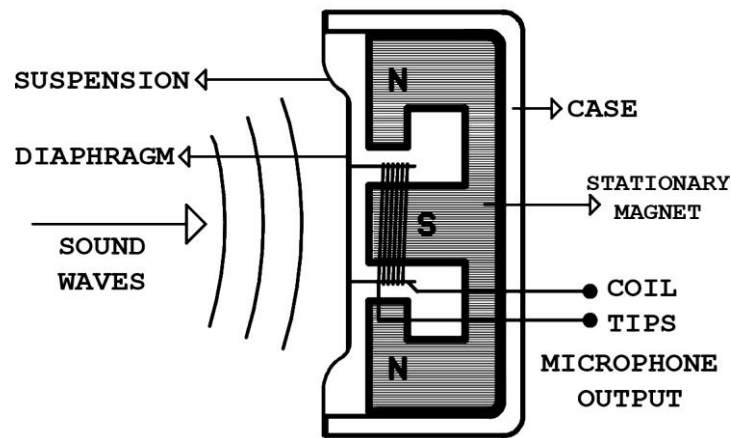

Figure 9. 2

The suspension is extremely flexible that it can move with the sound waves that hits the diaphragm. A coil, which is wrapped up on a very light skeleton, is fastened up to the center of the diaphragm. The weight of this movable coil is less than 0.1 grams and positioned into the space between the poles of a magnet made of alnico. The air gap between poles of the magnet is less than 1 mm.

The sound waves that moves the diaphragm pushes the diaphragm and the coil attached to it to the magnetic field. At the point where the first move ends diaphragm starts a harmonic in-out move. This harmonic motion induces an alternative voltage on the coil with value in between 1 and 10mVolts. An ideal microphone should provide a linear amplitude alternative voltage between the sound frequency band limits. However in practice, this is not the case. Dynamic microphones have fairly good characteristics in between mikrofonların "**60Hz-10KHz**" frequency band. The output impedance of dynamic microphones are in between "**50R-600R**" range. Low impedance prevents the sound amplifier to influence the microphone . If the input impedance of the sound amplifier in which the microphone will be plugged is high, an impedance transformer should be deployed in connection.

The sensitivity (ability to capture weak sounds) of the dynamic microphones are quite good, and they are mostly used in on-stage by singers.

Capacitive microphones: As the name implies, they are built using capacitor principles. Cross-section of a capacitive microphone is shown in Figure 9. 3.

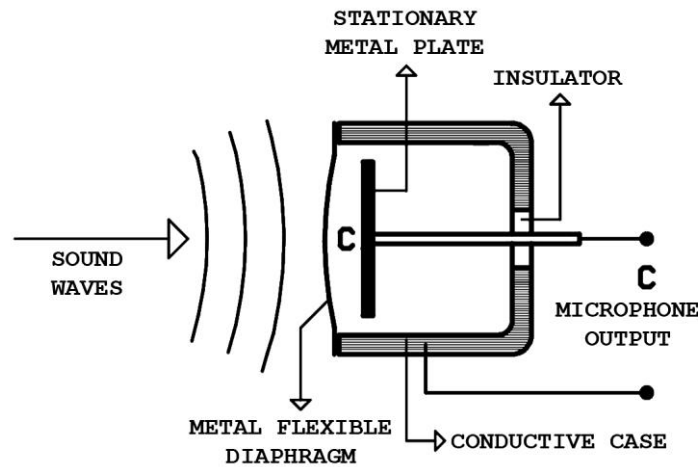

Figure 9. 3

The geometric shape of the diaphragm is like a plate and positioned very close to the stationary metal plate with no contacts. In this positioning, diaphragm and metal plate forms a capacitor. The dielectric of this capacitor is generally air. The sound waves hitting diaphragm naturally causes a movement of diaphragm, changing the distance of it to the metal plate , causing the capacity of the capacitor with respect to the sound waves. To convert this capacity change to an electrical signal, circuit in Figure 9. 4 or similar circuits are used.

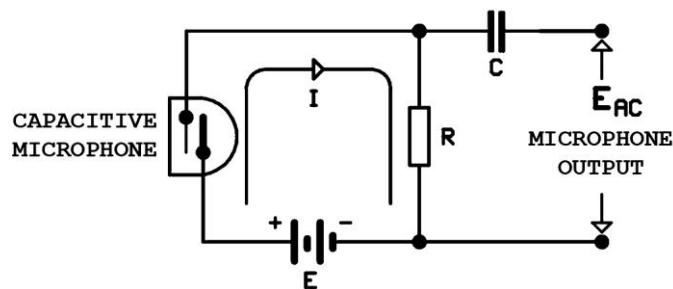

Figure 9. 4

The capacitive microphone and the resistor "R" is connected serially to the source terminals. Change in the value of the capacitor changes the circuit current, therefore changing the voltage across the pins of capacitive microphone and resistor "R". This variable voltage is taken from the capacitor C and the DC components are filtered out.

The output voltages of the capacitive microphones are in "**1mVolt-10mVolt**" range as in dynamic microphones. The frequency characteristics are generally flat between "**50Hz-15KHz**" band. The sensitivity of capacitive microphones are better than the dynamic ones.

9.3 SOUND AMPLIFIER

The electrical signal from the signal source is very weak. Sound amplifiers are the devices that amplify this signal without distorting its characteristics. Sound amplifiers are also called audio amplifiers. More than one sound amplifiers may be used to distribute sound or music to wide areas. The most crucial part of the system is sound amplifiers. Sistemin en önemli bölümü ses yükselticidir. A good sound amplifier must be a high gain and low distortion characteristics.

9.4 SPEAKER

The devices that convert the electrical signals to sound by an intermediate conversion to mechanical energy are called "**speakers**". Their structure resembles of dynamic microphone architecture, whereas the working principles are exact opposite of dynamic microphones. . Cross- section of a speaker microphone is shown in Figure 9. 5.

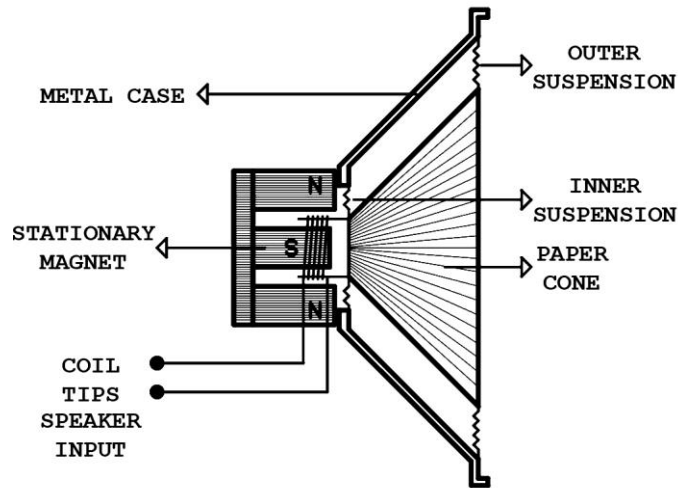

Figure 9. 5

A coil, freely movable with safe and flexible iner suspansion is placed between the air space of the poles of a special shaped stationary magnet. A hard material paper con is fixed on top of the coil, where the cone is connected to the case with a outer suspension. When an electrical signal is applied, the coil shows a magnetic behaviour, providing an axial second magnet to the stationary magnet. Based on the pole directions, these two magnets either pulls or pushes each other. Since the stationary magnet can not move, the coil moves inwards or outwards depending on pole directions. The magnitude of that move depends on the frequency and the amplitude of the electrical signal applied on it. The paper cone also moves with the movement of the coil, where the movement of the con vibrates the air in front of it. That air vibration produces the desired sound.

The speaker produces a force to the electrical signal, which is called speaker's impedance. The speaker impedance is defined as the force produced from the coil to an applied 1 KHz electrical signal. The impedance of the signal must be equal to the impedance of the sound amplifier. Another constraint arises from the fact that the current must pass across the coil when the electrical signal is applied, therefore the coil wire diameter should be sufficient to allow that current. The mechanical structure of the speaker should also have the shape and stiffness to cope with the coil's movement. The power factor of the speaker is defined as the maximum current and the ability to convert electrical signal to sound waves, and it must be well-matched to the sound amplifier.

A good speaker should convert all the frequencies in the sound frequency band to sound, however in practice it is not possible. For this reason, in order to listen high quality music, separate speakers are used to convert high, medium and low pitched frequencies.

The speakers produce some side effects to the sound amplifiers in addition to the impedance, such as coil and capacitance. In lab processes, those side effects are not wanted. So carbon resistors with the same impedance with the speakers are used in lab processes.

9.5 MEASURING THE GAIN IN SOUND AMPLIFIERS

The gain in amplifier is simply the ratio of the output signal to input signal. This gain shall be large and same for all the frequencies in the sound frequency band. (**20Hz – 20KHz range**). However, in practice, an equal gain in all frequency band can not be achieved. In low and high frequencies, generally the output signal's amplitude change. This situation will be analyzed in the frequency characteristic of the sound amplifiers.

The gain of the sound amplifiers is calculated as the logarithm of either the voltage or power ratio of output signal to input signal and labeled as "**Bell**" (**B**).

Example: $V_i=1\text{V}$ is applied to the input of a sound amplifier and $V_o=100\text{V}$ is measured at the output. What is the gain (**A**)?

$$A = \frac{V_i}{V_o} = \frac{100}{1} = 100 = 10^2 = 2 \text{ Bell.}$$

If the calculated ratio was 1000, the gain should be

$$A = 1000 = 10^3 = 3 \text{ Bell.}$$

As the examples suggest, a 1 Bell change is actually a very significant change. For this reason, decibel (**dB**), which is one tenth of bell is used. Decibel is also the unit of sound intensity. Desibel aynı zamanda ses şiddeti birimidir.

For a realization of decibel, we present some numerical values. The minimum allowable sound intensity for human ear is 6.5 dB, daily human chit-chat is around 100dB and dangerous sound intensity for our ears is 140dB.

The gain in terms of Decibel is

$$dB = Lg \frac{Po}{Pi} \text{ or } dB = Lg \frac{Vo}{Vi}$$

In formulas **Po** and **Pi** is output and input powers, respectively. The output powers of sound amplifiers can also be derived without using the currents as shown below.

$$P = E.I$$

$$P = E \cdot \frac{E}{R}$$

$$P = \frac{E^2}{R}$$

The "R" resistor is constants and the voltage value is squared so the power value is changing logarithmically. In order to sense the reception in human ear, a factor is applied to the formulas when the gain is evaluated from power or voltages. If the gain is calculated from power, the formula shown below is used.

$$A = 10Lg \cdot \frac{Po}{Pi}$$

If the gain is calculated from voltages then

$$A = 20Lg \cdot \frac{Vo}{Vi} \text{ formula is used}$$

Example:

The input power **Pi**=25mW is applied to a sound amplifier, and the output power **Po**=0.5W is measured. Evaluate the gain of the sound amplifier.

Solution:

$$A = 10Lg \cdot \frac{Po}{Pi} = 10Lg \frac{500}{25} = 10Lg 20$$

Lg20 can be found by calculators or logarithm tables as Lg20= 1,15 . So the result is

$$A = 10 \cdot 1,15 = 11,5dB$$

Example:

The input power $V_i=150\text{mV}$ is applied to a sound amplifier, and the output power $V_o=4\text{Volt}$ is measured. Evaluate the voltage gain of the sound amplifier.

Solution:

$$A = 20Lg \cdot \frac{V_o}{V_i} = 20Lg \cdot \frac{4000}{150} = 20Lg14,4$$

$Lg20$ can be found by calculators or logarithm tables as $Lg14,4= 1.30$. So the result is

$$A = 20 \cdot 1,30 = 26\text{dB}$$

9.6 MEASURING THE OUTPUT POWER OF THE SOUND AMPLIFIERS

As mentioned, the output power is the maximum power value with no distortions on the output load. For evaluating this value, a carbon resistor with equal impedance of the speaker is used instead of a speaker. For the input of the sound amplifier, 1Khz sinusoidal signal is applied as a world standard.

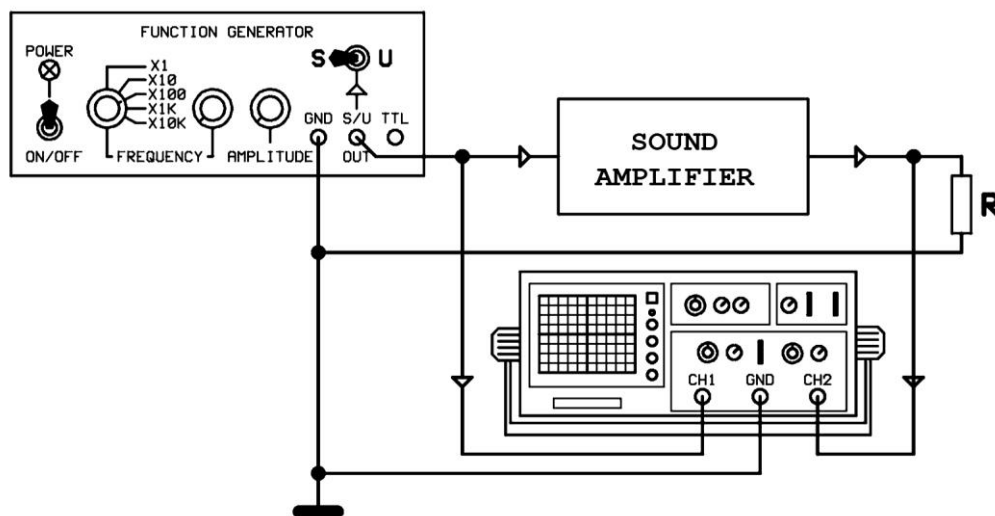

Figure 9. 6

In Figure 9. 6, the diagram of the measurement circuit for output power of sound amplifier is shown. The amplitude of the input signal is incremented from zero amplitude slowly. By using the oscilloscope, the moment of distorted output signal is captured and the incrementation is stopped at this point. The output signal's amplitude is measured as it is maximum power with no distortion.

Example:

The output load of a sound amplifier is $Z=4$ Ohms. If the maximum output signal value with no distortions is 5 Volts, evaluate the output power.

Solution:

$$E = 0,707.E_{MAX}$$

$$E = 0,707.5$$

$$E = 3,5v$$

$$P = \frac{E^2}{Z} = \frac{3,5^2}{4} = \frac{12,25}{4} = 3,0W$$

In order to obtain accurate results, the output load should be equal to the speakers' impedance, since the speaker can not be used due to its minor capacitive and inductive effect. The output power must be the highest power value that can be applied to that ohmic output load.

When the power measurement is done, the amplitude of the input signal must also be known. The amplitude of the input signal can be easily adjusted by the pre circuits in the sound amplifiers.

9.7 DERIVING FREQUENCY CHARACTERISTICS OF SOUND AMPLIFIERS

The circuit shown in Figure 9. 6 is used for obtaining the frequency characteristics of the sound amplifiers. When the output power is decreased, the distortion amount is also decreased. When obtaining frequency characteristics, the input signal should be a sinusoidal signal with frequency 1 KHz, with the amplitude obtained by the maximum power value. Assume the distortion-free output signal amplitude(peak to peak) for 1Khz standart is $V_{opp}=5$ Volt and the input signal amplitude at that point is $V_{opp}=400$ mV peak to peak. Adjusting the input signal frequency as shown in the values of table 16.7, and reading the output signal amplitude by oscilloscope, we obtain the values shown in Figure 9. 7.

UGpp=400mV CONSTANT			UGpp=400mV CONSTANT		
NUMBER	FREQUENCY	Uopp (V)	NUMBER	FREQUENCY	Uopp (V)
1	20 Hz	4,4	9	500Hz	5,0
2	30 Hz	4,6	10	1 KHz	5,0
3	40 Hz	4,7	11	3 KHz	5,0
4	50 Hz	4,8	12	5 KHz	5,0
5	80 Hz	4,9	13	10 KHz	5,0
6	100 Hz	5,0	14	14 KHz	4,4
7	200 Hz	5,0	15	15 KHz	4,2
8	300 Hz	5,0	16	20 KHz	4,0

Figure 9. 7

If we examine the values of output signal in table, the output signal is constant in the band 100Hz-5KHz as 5.0 volts. This voltage value is accepted as reference line in the characteristic curve. In the plot, the x axis is the reference line. In the required mathematical operations, either of the alternative current values (**AC**) (**peak to peak, maximum, effective**) can be used.

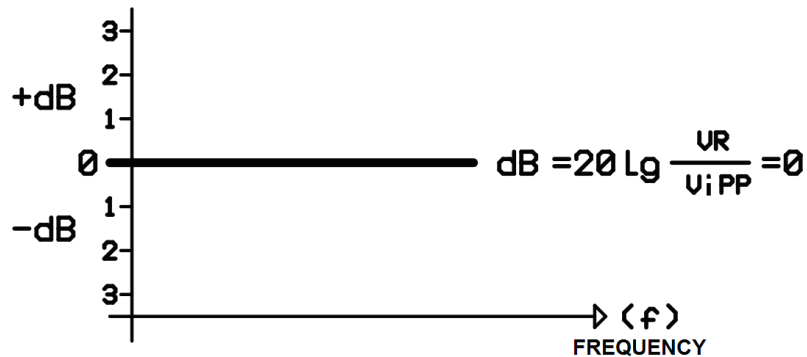

Figure 9. 8

The reference line is shown in Figure 9. 8. If the output reference signal is smaller then the reference voltage, then the values of dB values are accepted as negative and plotted in -dB part.. As the values we obtained in Figure 9. 7 are all smaller then the reference voltage, these points constitutes the negative points of the characteristic curve, and to be plotted in the -dB area.. If the output signal was higher then reference voltage, then the dB values were accepted to be positive and to be plotted in +dB part. In Figure 9. 7, there are no such points.

$$\text{On reference line; } dB = 20.Lg.\frac{VR}{Vopp}$$

$$\text{If } VR > VC_{pp}; -dB = 20.Lg.\frac{VR}{Vopp}$$

$$\text{If } VR < VC_{pp}; +dB = 20.Lg.\frac{VR}{Vopp} .$$

The decibel values for all steps in Figure 9. 7 are evaluated mathematically. The obtained values are drawn on the frequency- decibel axes for plotting the frequency characteristics of the sound amplifier.

20Hz

$$-dB = 20.Lg.\frac{VR}{Vopp} = 20.Lg.\frac{5,0}{4,4} = 20.Lg1,136 = 20.0,055 = 1,1$$

30Hz

$$-dB = 20.Lg.\frac{VR}{Vopp} = 20.Lg.\frac{5,0}{4,6} = 20.Lg1,086 = 20.0,035 = 0,71$$

40Hz

$$-dB = 20.Lg.\frac{VR}{V_{opp}} = 20.Lg.\frac{5,0}{4,7} = 20.Lg1,063 = 20.0,026 = 0,53$$

50Hz

$$-dB = 20.Lg.\frac{VR}{V_{opp}} = 20.Lg.\frac{5,0}{4,8} = 20.Lg1,041 = 20.0,071 = 0,34$$

80Hz

$$-dB = 20.Lg.\frac{VR}{V_{opp}} = 20.Lg.\frac{5,0}{4,9} = 20.Lg1,020 = 20.0,008 = 0,17$$

In between 100Hz - 10KHz dB is equal to 0

14KHz

$$-dB = 20.Lg.\frac{VR}{V_{opp}} = 20.Lg.\frac{5,0}{4,4} = 20.Lg1,136 = 20.0,055 = 1,10$$

15KHz

$$-dB = 20.Lg.\frac{VR}{V_{opp}} = 20.Lg.\frac{5,0}{4,2} = 20.Lg1,190 = 20.0,075 = 1,50$$

20KHz

$$-dB = 20.Lg.\frac{VR}{V_{opp}} = 20.Lg.\frac{5,0}{4,0} = 20.Lg1,25 = 20.0,096 = 1,93$$

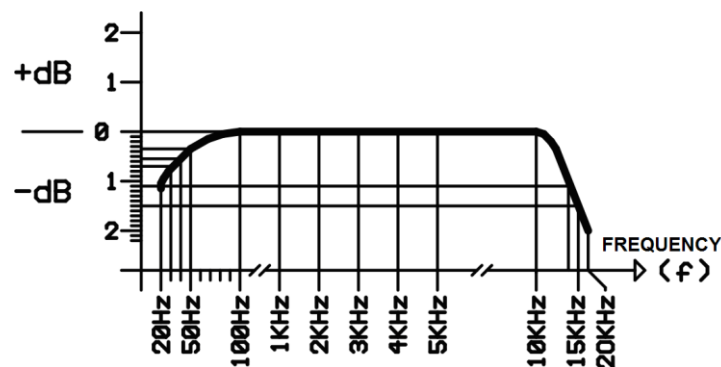

Figure 9. 9

High quality sound frequency amplifiers (**High Fidelity or HI-FI**) are produced since 2006. Those devices have frequency characteristics in sound frequency band 20Hz-40KHz and output powers reaching to 1000Watts. These devices have also distortions at maximum power lower then %1

9.8 TRANSISTORED SOUND AMPLIFIERS

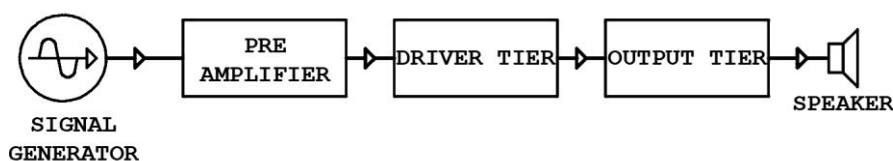

Figure 9. 10

In Figure 9. 10, a block diagram of a transistored sound amplifier is shown. The circuit is composed of three tiers.

Preamplifier Tier: Amplifies the electrical signal coming from the signal source without distorting its characteristics, only increases the amplitude. Sometimes they are built by using more than one transistors.

Driver Tier: Amplifies the current. It may amplify the preamplifier output signal in a small amount, however its main duty is protecting the preamplifier tier from the output tier.

Output Tier: Amplifying the driver tier's output signal in terms of current and voltage, and conveys the amplified signal to speaker.

The driving of signal across the tiers is called "**coupling**". In sound amplifiers, either direct coupling or capacitive coupling is used.

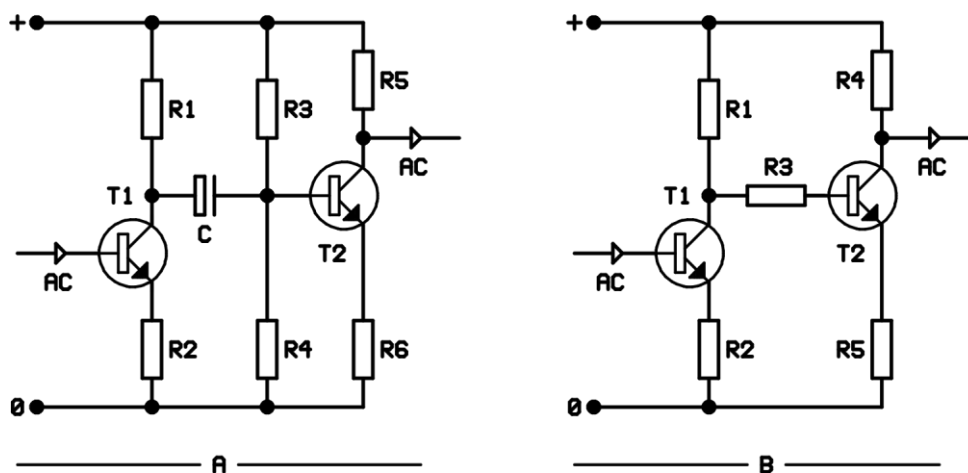

Figure 9. 11

In Figure 9. 11A, capacitive coupling is shown. In the collector of T1 transistor, both direct current and alternative current signal is collected. Capacitor "C" allows only alternative current signal to be passed onto T2 base, effectively prevents the T1 DC voltage to be bypassed onto T2 base. In Figure 9. 11B's direct coupling is shown. The alternative signal on the collector of T1 transistor is applied to T2 transistor's base with the R3 resistor. R3 resistor also supplies the base voltage of T2 transistor.

The frequency characteristics of direct coupling sound amplifiers are better, because the resistors force the same impedance to all signals in different frequencies, whereas the capacitors provide higher impedance to lower frequencies and lower impedance to higher frequencies. For this reason, direct coupling should be preferred.

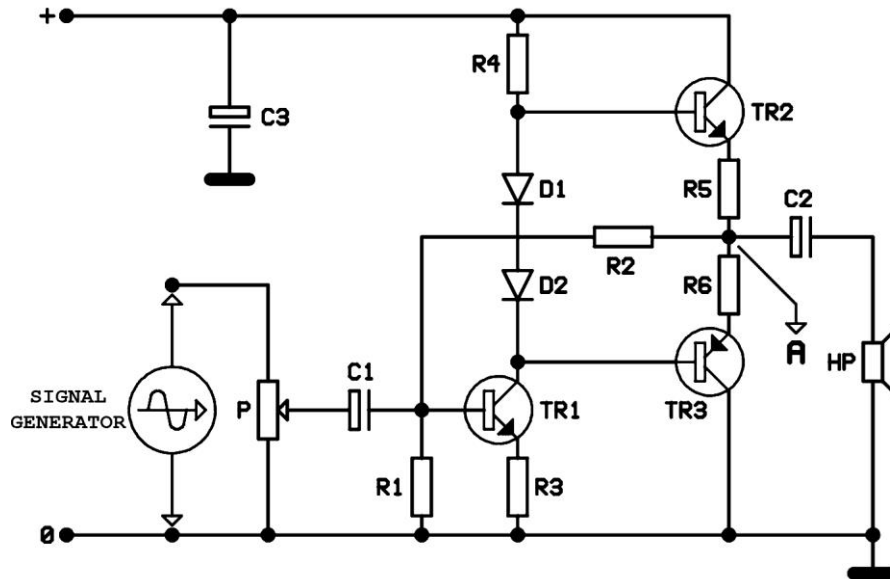

Figure 9. 12

A sound amplifier made with transistors is shown in Figure 9. 12'de transistörle yapılmış ses yükseltici görülmektedir. The potentiometer "P" Works as a voltage divider and adjusts the sound of the speaker by driving the required amount of the signal coming from the signal generator to the amplifier. C1 capacitor is coupling capacitor. TR1 transistor works both as a preamplifier and driver. The alternative signal at the collector of TR1 is applied to TR2-TR3 bases by direct coupling. TR2 and TR3 are output tier transistors, where they are NPN and PNP types respectively. The connection type of these two transistors shown in Figure is called "push-pull" connection. In push pull connection, same signal is applied to bases of both transistors. In positive cycles of input signal, NPN type transistor's conductivity is increased, where PNP type transistor's conductivity decreases and in negative cycles vice-versa. So, in positive alternations NPN, and in negative alternations PNP transistor is conductor.

In push-pull connections the output signal is taken from the connected emitter pins of the transistors (**shown as point A**) and drives the same load. The C2 capacitor is also a coupling capacitor. R4 resistor provides base currents. D1-D2 diodes balances base currents of two transistors. R5-R6 resistors limit the output currents passing on output transistors. In a balanced push pull connection, half of the source voltage is obtained at point A. Note that at point A, there is both a DC and AC signal.

Both these signals provide TR1 transistors base voltage across R2 resistor. Alternative component reverses the base voltage and provides negative feedback. In amplifier circuits, negative feedback reduces the gain slightly but provides smoother frequency characteristics.

R1 resistor is TR1 transistor's base resistor. R3 is the emitter resistor of TR1. C3 is used for cleaning unwanted AC signals from the power supply. Its working principle is completely opposite of coupling capacitors, hence it is called "**decoupling capacitor**".

The output of the sound amplifier is about 0.25 Watts. A efficient amplifier in this range should consume less then 15mA in idle (**with no signal in input**) and less than 100mA in full load (**output at 0.25Watt**).

Nowadays, low powered (less than 10W) transistored sound amplifiers are not used widely, rather integrated sound amplifiers are preferred. Integrated sound amplifiers, or amplifiers on chip are more economical and have better frequency characteristics.

9.9 ANALYSIS OF INTEGRATED SOUND AMPLIFERS

Integrated sound amplifiers are used when small powers are sufficient (smaller than 10 Watts) for their savings in size and Money. Different integrated amplifiers are shown in Figure 9. 13.

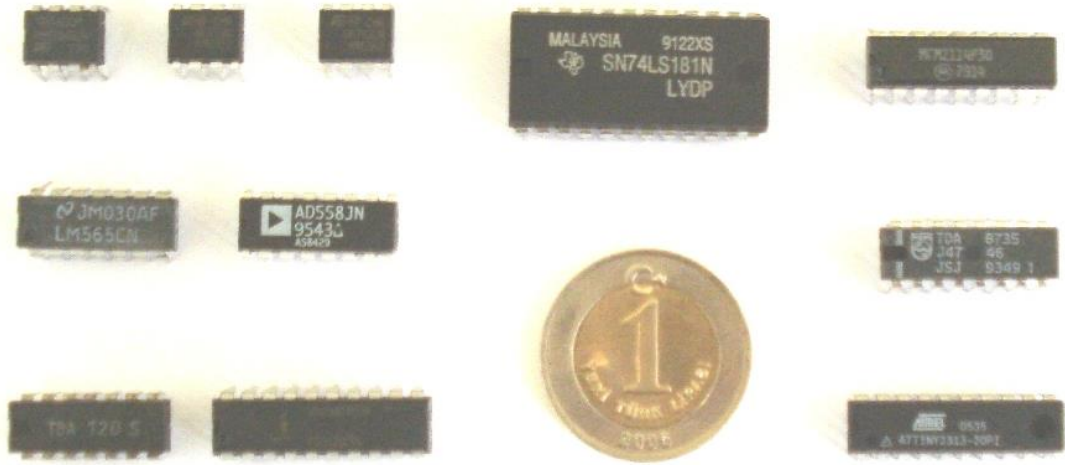

Figure 9. 13

In Figure 9. 14, a 1W power output sound amplifier made from TBA 820 chip is depicted. The circuit diagrams and frequency characteristics of the integrated sound amplifiers can be found in the providers specification sheets and catalogs.

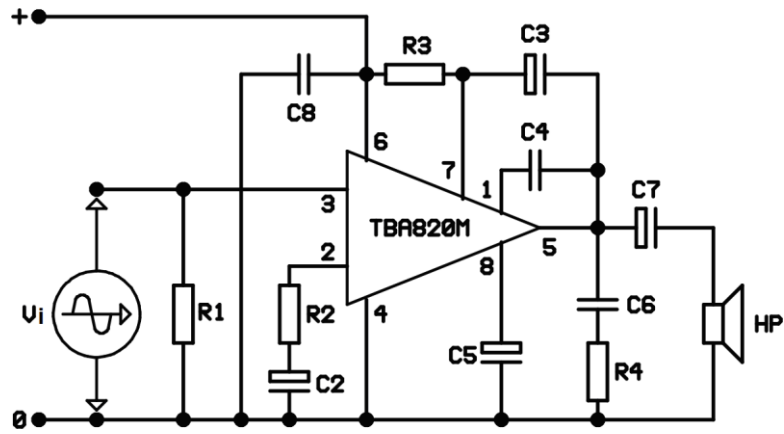

Figure 9. 14

In this kind of sound amplifiers, changing the values of the surrounding circuit elements degrades performance. The adjustable elements must also be searched from the chip supplier resources. As an example, there is a 6k resistor between 2. and 5. legs of TBA 820 M chip. The gain of the circuit is dependant of this resistor and R2 resistor.

TBA 820M integrated sound amplifier voltage gain is (**A**);

$$A = 1 + \frac{6K}{R2}$$

FIELD EFFECT TRANSISTORS

10.1 INTRODUCTION

Bipolar junction transistors (**BJT**) are the ones with current control.

Field Effect Transistors (FET) work with voltage control, they are economical and have a simple structure.

High input impedance, good temperature stability, high switching speed, and low level of noise are the advantages of FET's. High output impedance, lower gain compared to BJT, narrow frequency bands and fragility is the disadvantages of FET.

Because of the fact that input impedance of FET is high, the signal supply is not charged. So, FET is commonly used as input in integrated circuits.

FET can be degenerated while the process of montage because of the static electricity on the human body. Because of that there must not be static electricity on human body during the process. This can be possible by using anti-static materials.

10.2 JFET

Junction Field Effect Transistors (JFET) have generally three terminals. They are produced in two types: N channeled and P channeled. Characteristics of JFETs are same regardless of their type. DC bias voltage and current have opposite directions. Names of JFET terminals: DRAIN, GATE and SOURCE. In terms of process, collector is the equivalent of drain, base is the equivalent of gate and emitter is the equivalent of source. Symbols and structures of P and N type JFETs are shown in figure 17.1

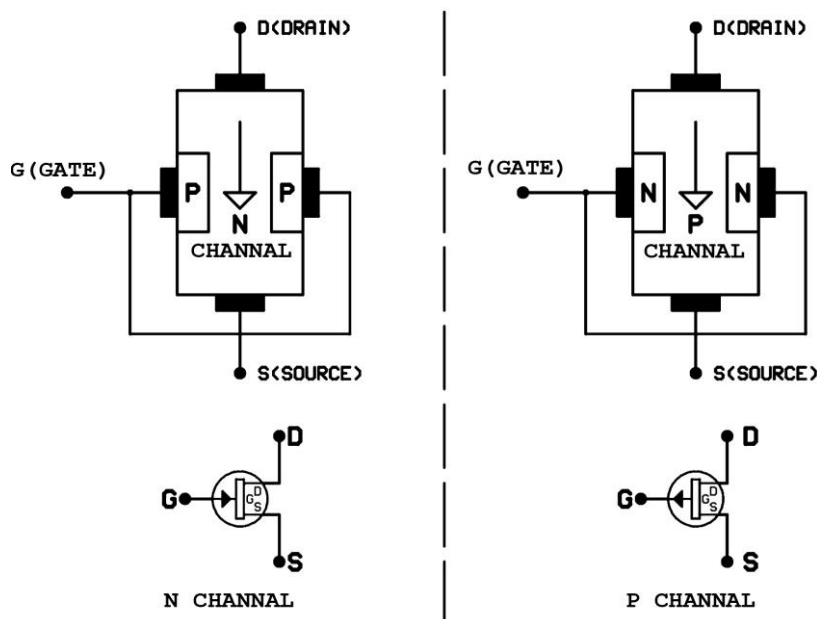

Figure 17.1

The direction of the arrow on the gate terminal indicates the channel type of JFET. If it is inwards then JFET is N type and if it is outwards then JFETs is P type. General structures of two types are similar but N and P materials are exchanged placed. N type is more commonly used. So, we will examine N type JFET.

When the base terminals of BJT are idle, current does not flow between collector-emitter. Yet, a low current flows between Drain-Source when the gate terminal is idle in JFETs. This can be prevented by connecting a resistor between gate-chassis (**ground**).

It is essential to know two important parameters when designing JFET circuit. These are V_P (**Gate-Source pinch-off voltage**) and I_{DSS} (**Drain-Source saturated current**). Let's explain these two parameters in figure 17.2

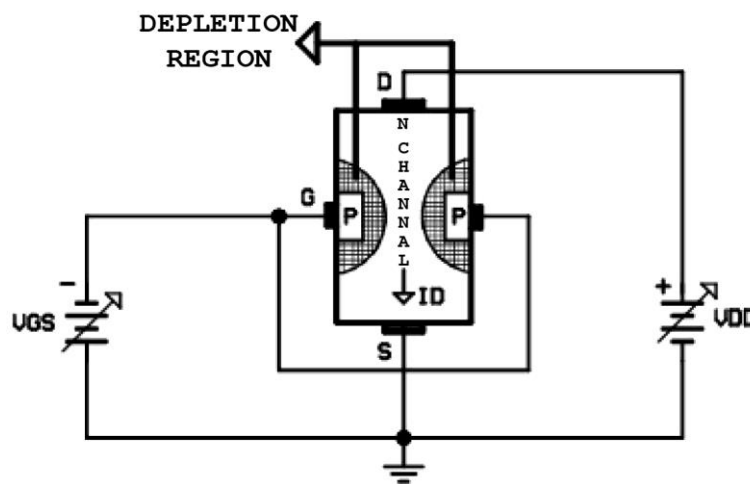

Figure 17.2

Inverse biased voltage (which is applied between gate-source) generates a depletion region in channel region. Width of this region is directly proportionate to the magnitude of inverse biased V_{GS} voltage. Increase of V_{GS} voltage at opposite direction means that the negativity of gate is also increasing. Increasing negativity of gate widens the depletion region. This results in the narrowing of channel and I_D current decreases. V_{GS} voltage (when the I_D current is zero (**0**)) is the **V_P (Gate-Source pinch-off voltage)**.

When the V_{GS} voltage is "**0**", if you increase $V_{DD}=V_{DS}$ voltage slowly, depletion region will be narrowed and I_D current increases slowly. After a certain V_{DD} voltage magnitude, I_D is constant even if V_{DD} continues to increase. This certain value (when the I_D is constant) is the **I_{DSS} (Drain-Source saturated current)**.

If a forward voltage is applied between drain and source of an N channeled JFET, drain becomes more positive than source and there appears a current flow from drain to source. Practically, this current is controlled by a second voltage in opposite direction applied between gate and source.

10.3 INPUT CHARACTERISTICS OF JFET

Input characteristics of JFET is the curve that indicates the effects of variable input voltages to output voltage, when the V_{DS} (**drain-source voltage**) is constant. This curve is also called transfer characteristics.

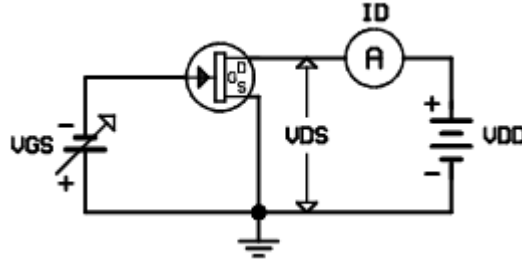

Figure 17.3

The circuit in figure 17.3 is used for deriving the input characteristics. Let's decrease V_{GS} voltage (starting from zero) while stabilizing V_{DD} voltage at a certain value. And type the I_D (**drain current**) at every stage to a table like in figure 17.4; if the values in the table are drawn as I_D in vertical axis and V_{GS} in horizontal axis, then the input characteristics of JFET is derived.

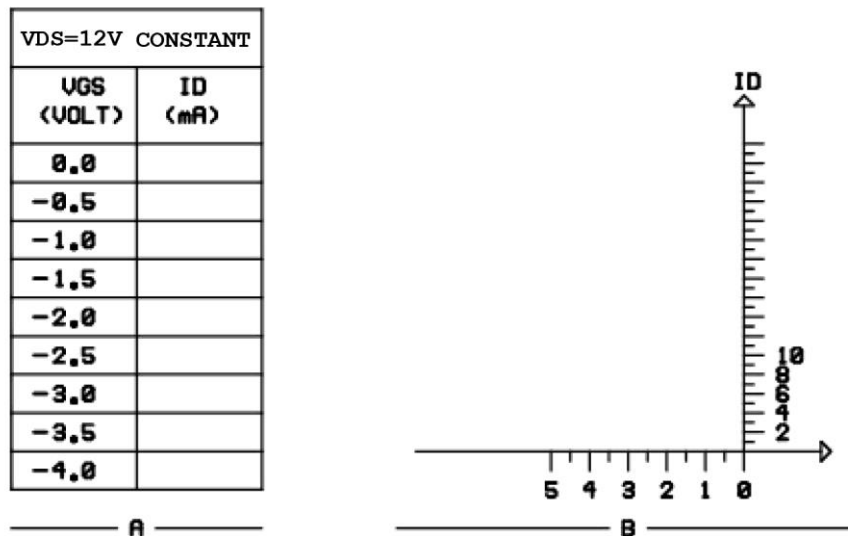

Figure 17.4

When the experiments are carried out, JFET gets heated and its resistance increases at the steps when the drain current is high. As a result, drain current starts to decrease and the temperature can harm JFET. So, the experiments should be done as quickly as possible.

10.4 OUTPUT CHARACTERISTICS OF JFET

Output characteristics of JFET is the curve that indicates the effects of variable V_{DS} (**drain-source voltage**) voltages to the output voltage when the V_{GS} (**gate-source voltage**) is constant.

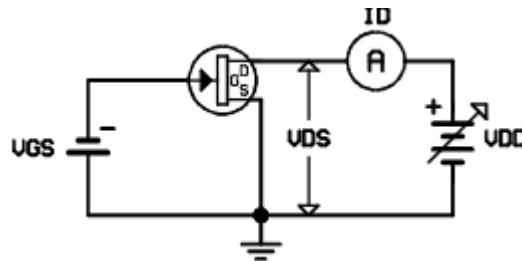

Figure 17.8

When V_{GS} is constant at the circuit in figure 17.8, adjust the $V_{DD}=V_{DS}$ to different values and type the I_D currents for each step. Draw the curve as the I_D at vertical and $V_{DD}=V_{DS}$ at horizontal axis. This curve is the output characteristics of JFET.

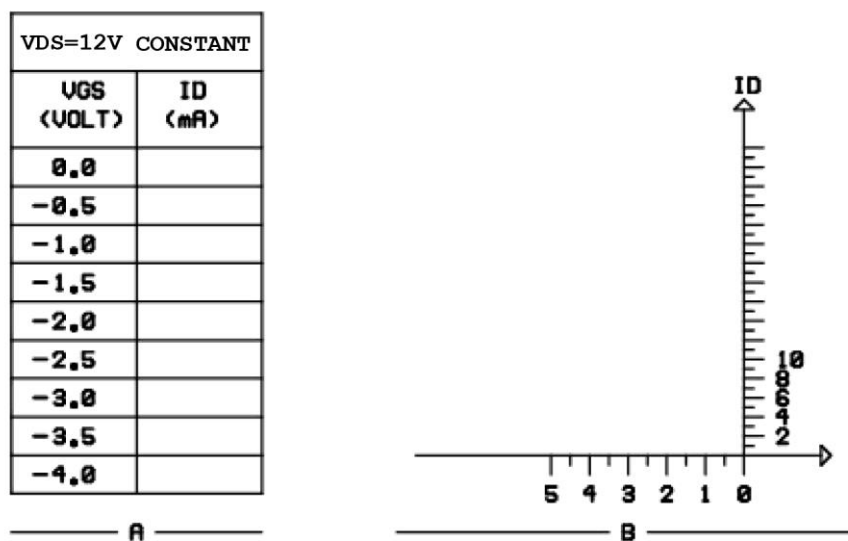

Figure 17.9

When the experiments are carried out, JFET gets heated and its resistance increases at the steps when the drain current is high. As a result, drain current starts to decrease and the temperature can harm JFET. So, the experiments should be done as quickly as possible.

10.5 USING JFET AS AMPLIFIER

JFETs are connected as drain ground, gate ground and source ground depending on their types. The most commonly used one is source ground.

10.6 DRAIN GROUND CONNECTION

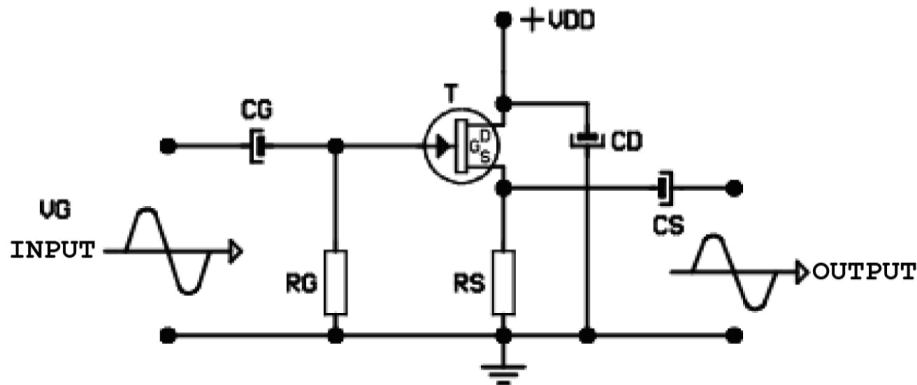

Figure 17.15

In figure 17.15, drain ground connection is shown. Drain is grounded as AC by the CD capacitor. In this connection type, input signal is applied to drain over gate and CG capacitor. Output signal is taken by CS capacitor between source and drain.

The properties of drain ground circuit are as follows:

<i>Input impedance (Z_i):</i>	<i>High</i>
<i>Output impedance (Z_o):</i>	<i>Low</i>
<i>Voltage gain (AG):</i>	<i>None</i>
<i>Current gain (AI):</i>	<i>High</i>
<i>Power gain (AP):</i>	<i>Medium</i>
<i>Phase difference :</i>	<i>None</i>

Drain ground connection is used as **buffer** to prevent the signal supply from being affected by the circuit.

10.7 GATE GROUND CONNECTION

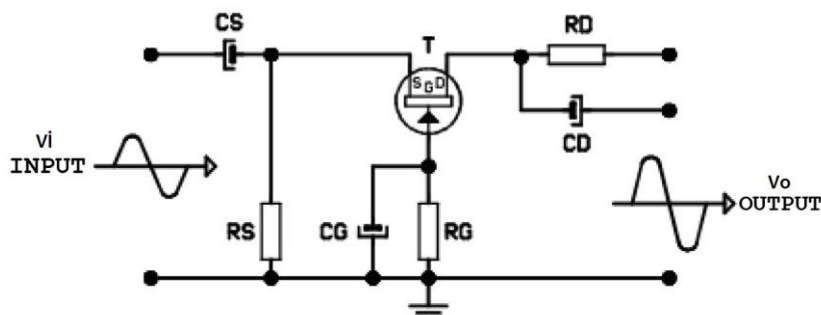

Figure 17.16

In figure 17.16, gate ground connection is shown. Gate is grounded as AC by CG capacitor. Input signal is applied between source and gate. Output signal is taken from between gate and drain.

The properties of gate ground circuit are as follows:

<i>Input impedance (Z_i):</i>	<i>Low</i>
<i>Output impedance (Z_o):</i>	<i>Medium</i>
<i>Voltage gain (AG):</i>	<i>Medium</i>
<i>Current gain (AI):</i>	<i>Medium</i>
<i>Power gain (AP):</i>	<i>Low</i>
<i>Phase difference :</i>	<i>None</i>

Gate ground connection is generally used as impedance adapter.

10.8 SOURCE GROUND CONNECTION

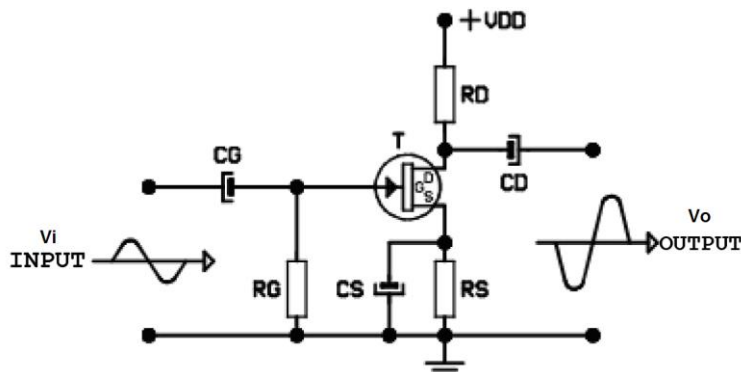

Figure 17.17

In figure 17.17, source ground connection is shown. Source is grounded as AC by CS capacitor. Input signal is applied between gate and source. Output signal is taken from between drain and source.

The properties of source ground connection are as follows:

<i>Input impedance (Z_i):</i>	<i>High</i>
<i>Output impedance (Z_o):</i>	<i>Medium</i>
<i>Voltage gain (AG):</i>	<i>High</i>
<i>Current gain (AI):</i>	<i>Low</i>
<i>Power gain (AP):</i>	<i>Medium</i>
<i>Phase difference :</i>	<i>180⁰</i>

Source ground connection is generally used in voltage amplifier and switching circuits.