

# **ELECTRONICS LAB.**

## **PART 9**

**Yrd. Doç. Dr. Taha İMECİ**

**Arş. Gör. Ezgi YAMAÇ**

**Arş. Gör. Ufuk ŞANVER**

**İSTANBUL COMMERCE UNIVERSITY**

## Contents

<b>OSCILLATORS</b> .....	<b>2</b>
11.1 INTRODUCTION .....	2
11.2 RC PHASE SHIFT OSCILLATORS.....	5
11.3 LC OSCILLATOR.....	6
11.4 HARTLEY OSCILLATOR .....	7
11.5 COLPITTS OSCILLATOR .....	9
11.6 CRYSTAL OSCILLATOR .....	10
11.7 WIEN BRIDGE OSCILLATORS .....	11

# OSCILLATORS

## 11.1 INTRODUCTION

Oscillator is a circuit which generates sine, triangle or square wave signal. Main components of oscillators are capacitors and coils. We know that capacitors store electrical energy for long term and coils store energy for short term. The coils are wrapped generally in two ways.

**1. Simple Coils:** Conductors are wound without touching each other

**2-Honeycomb Coils:** Isolated conductors are wound in diagonal shape.

Simple coils are commonly used in oscillators. The inductance of simple coils is calculated through the following formula:

$$L = K \cdot N^2 \cdot D \cdot 10^{-3}$$

**In Formula:**

**L**=Coil inductance ( $\mu\text{H}$ )

**K**=Coefficient

**N**=Number of turns

**D**=Diameter of coil (**cm**)

(**K**) Coefficient can be calculated by the physical size of coil.

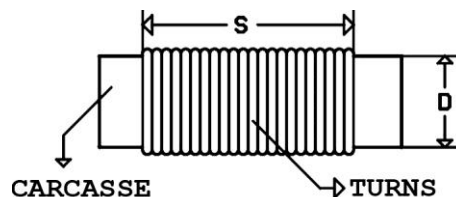

**Figure 11. 1**

$$K = \frac{100D}{KD + 11S}$$

**In Formula;**

**D**=Diameter of coil

**S**=Length of winding.

If variable signal is taken from the circuit output of coil and capacitor by applying only direct current (**DC**) to the circuit, this means that the circuit is making oscillation. Oscillation can be explained in a circuit which consists of parallel connection of a capacitor and a coil. This circuit is called **tank circuit** or **resonance circuit**.

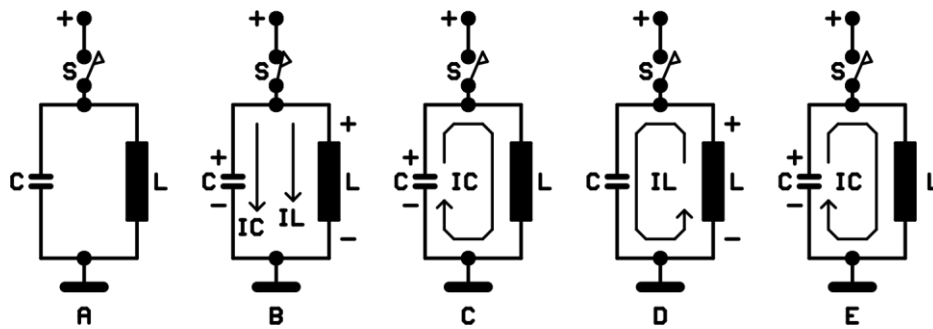
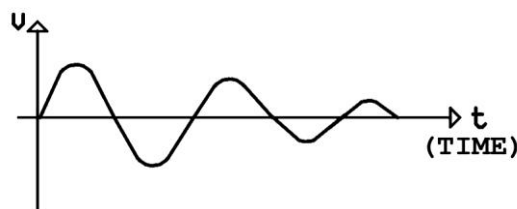

**Figure 11. 2**

In Figure 11. 2A, if the S switch is off in circuit,  $I_C$  and  $I_L$  currents starts to flow. "C" capacitor is charged to circuit voltage. "L" coil stores an amount of energy. This is shown in Figure 11. 2B If S switch is opened capacitor starts to discharge through coil as seen in Figure 11. 2C

This increases the energy on coil. The energy on the coil becomes more than the energy on capacitor. At that moment, as seen in Figure 11. 2E, discharges the energy on itself towards capacitor (in opposite direction to the discharge of capacitor). This time the energy of capacitor starts to increase. As in Figure 11. 2E, capacitor starts discharging the energy on itself towards coil. It is observable that Figure 11. 2E is the same as Figure 11. 2C; processes are repeated. If there is no energy loss in capacitor and coil, this repetition continues infinitely. Yet, there is loss and the operation ends slowly with the decrease of energy.

If the current flowing through the circuit is examined with an oscilloscope it will be seen that it is like a sine curve. Amplitude of sine signal slowly decreases and oscillation ends. In Figure 11. 3, wave form of such a signal is shown. Such oscillations are called "**damped oscillations**".



**Figure 11. 3**

Continuity of oscillation is maintained by applying a part of an output signal to input in positive direction. Oscillators are actually rectifiers which the output signal is applied to input as feedback. The amplitude and frequency of output signals of oscillators should be constant. Amplitude is controlled by the bias of the rectifier. Frequency is controlled by the frequency controller unit or phase shifter circuit. Bloc schema of oscillator will be shown in Figure 11. 4

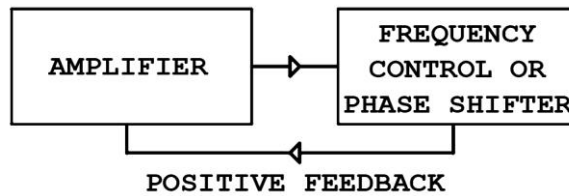

**Figure 11. 4**

Signal frequency of oscillator is determined by the coil and capacitor values. Coils and capacitors present a variable (depending on frequency) resistance to circuit current when used in AC circuits. The resistance of coil is called inductive reactance and symbolized by (**XL**). The resistance of capacitor is called capacitive reactance and symbolized by (**XC**). Inductive reactance in formula:

$$XL=2\pi FL$$

Capacitive reactance in formula:

$$XC = \frac{1}{2\pi FC}$$

**In Formula:**

**XL**=Inductive reactance (**R (ohm)**)

**XC**=Capacitive reactance (**R (ohm)**)

**L** =Coil value (**Henry**)

**C** =Capacity value (**Farat**)

Inductive reactance increases directly proportionate to frequency and capacitive reactance decreases inversely proportionate to frequency. In other words, regardless of their value, inductive reactance will be equal to the capacitive reactance at a specific frequency value in an AC circuit.

This specific frequency is called resonance frequency and symbolized by (**Fo**). The resonance frequency in formula:

$$Fo = \frac{1}{2\pi\sqrt{L.C}}$$

**In Formula:**

**FO**=Resonance frequency (**hertz**)

**L**=Coil value (**Henry**)

**C**=Capacity value (**Farat**)

Resonance frequency is the oscillation frequency of oscillator. Sine signal generator oscillator types are examined in Y-0016/014 module of our experiment set.

## 11.2 RC PHASE SHIFT OSCILLATORS

Theoretically, RC phase shift oscillator is the most basic oscillator.

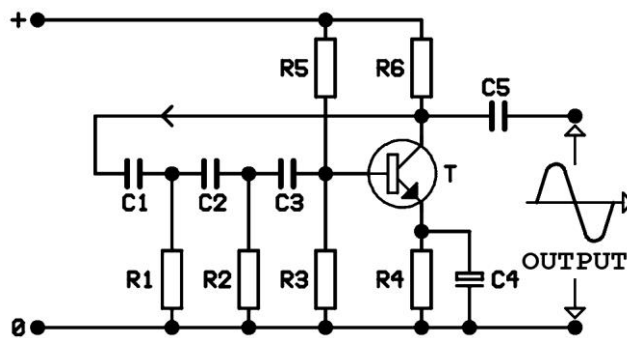

**Figure 11. 5**

In Figure 11. 5, RC phase shift oscillator is shown. It is an emitter ground amplifier circuit. There is a phase  $180^{\circ}$  difference of between input and output signals of emitter ground amplifier. If the phase of signal in collector of transistor is shifted  $180^{\circ}$  and applied to base then a positive feedback is done. Phase shift is done by using 3 RC circuits. Every RC circuit does a shift of  $60^{\circ}$ . As a result, coil and capacitor values are equal in RC circuits. Resistor values are:  $R_1=R_2=R_3=10K$ , capacitor values are:  $C=C_1=C_2=C_3=1nF$ . The total of three system's phase shift is  $180^{\circ}$ . This phase shift of  $180^{\circ}$  is only valid at only one specific frequency value. There is feedback at only that frequency value. As a result, output signal is a sole sine signal.

Oscillation frequency of circuit (**Fo**):

$$F_o = \frac{1}{4,44.\pi.R.C}$$

### **In Formula:**

**Fo**= Oscillation frequency

**R**= Resistance (**ohm**)

**C**= Capacity (**farat**)

RC phase shift oscillators are used as signal supply in sound frequency circuits. Output signal of this oscillator is easily affected by heat and changes in feedback voltage, so, they are not used commonly.

## 11.3 LC OSCILLATOR

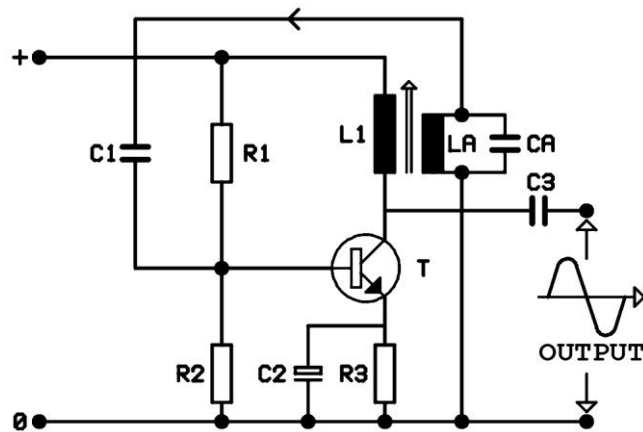

**Figure 11. 6**

In Figure 11. 6, LC oscillator is shown. It is an emitter ground transistor circuit. A coil is used in the structure of transistor as the collector load of transistor. Primary of transformer is L1 coil and secondary is LA coil. Form of circuit is the transformer coupling. It is also called magnetic coupling. Primary and secondary terminals of transformer should be connected in order to prevent positive feedback. Magnitude of feedback can be adjusted by the winding ratios of transformer.

Oscillation frequency of LC oscillator can be calculated by the following formula:

$$F_o = \frac{1}{2\pi\sqrt{LA.CA}}$$

Coils with ferrite core are used in our experiment set. Coil inductance and oscillation frequency can be changed by altering the core. Amplitude of output signal changes depending on the oscillation frequency. Bias of transformer should be consistent with the expected amplitude.

## 11.4 HARTLEY OSCILLATOR

*Hartley oscillator is a commonly used oscillator. It can be set as serial or parallel Hartley depending on the connection of tank circuit. In Figure 11. 7, serial Hartley oscillator is shown. **FET transistor** is used as amplifier.*

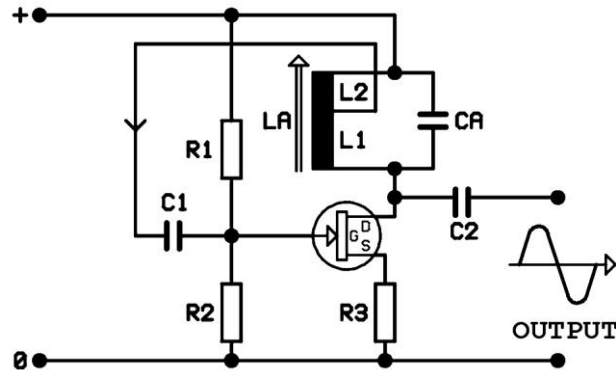

**Figure 11. 7**

*In Figure 11. 7, tank circuit is placed between drain terminal of fet transistor and supply. Circuit current passes through tank circuit coil in serial Hartley oscillator. Tank circuit consists of CA capacitor and LA coil. LA coil consists of the serial connection of L1 and L2 coils: **LA=L1+L2**. winding ratio of L1 and L2 coils determine the feedback value.*

*Oscillation frequency of circuit:*

$$F_o = \frac{1}{2\pi\sqrt{LA.LC}}$$

*The values in formula are main units.*

*Parallel Hartley oscillators are more commonly used compared to serial Hartley because tank circuit coil is isolated from the circuit current. In our experiment set, parallel oscillator is examined.*



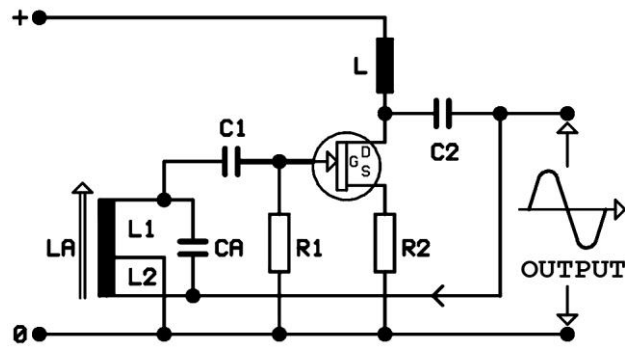
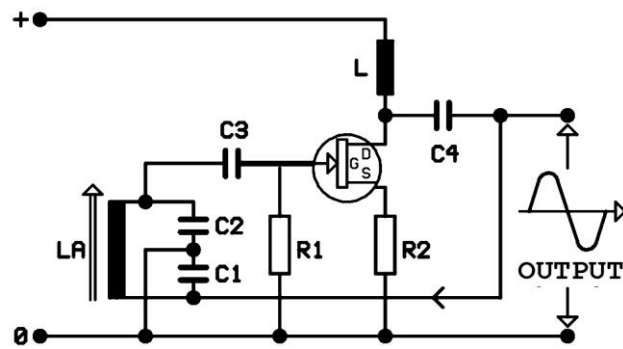

**Figure 11. 8**

In Figure 11. 8, parallel Hartley oscillator is shown. Tank circuit components are CA capacitor and LA coil. There is no relation between the circuit current and tank circuit coil. The operation of the circuit is the same as emitter ground amplifier. Oscillation frequency of circuit is the same as serial Hartley oscillators. LA coil is selected as ferrite core. By adjusting the core, coil inductance and oscillation frequency can be adjusted.

Load of FET transistor is the coil with the value of 100mH. Coil presents great opposition to high frequency signals thus preventing generated signals to reach supply. It ensures that signal is transmitted to output terminals through C2 coupling capacitor.

## 11.5 COLPITTS OSCILLATOR



**Figure 11. 9**

In Figure 11. 9, colpitts oscillator is shown. Tank circuit consists of LA coil, L1 and L2 capacitors. Magnitude of feedback for circuit depends on the C1 and C2 capacitor values. It is required that **C2 > C1** for oscillation to happen. C1 and C2 capacitors are serially connected.

If we call the capacitor of tank circuit as (**C**), then, in formula:

$$\frac{1}{C} = \frac{1}{C1} + \frac{1}{C2} \text{ or,}$$

$$C = \frac{C1.C2}{C1+C2}$$

Oscillation frequency of circuit (**Fo**):

$$Fo = \frac{1}{2\pi\sqrt{LA.C}}$$

Coils with ferrite core are used in our experiment set. Coil inductance and oscillation frequency can be changed by adjusting the core. Load of FET transistor is the coil with the value of 100mH. Coil presents great opposition to high frequency signals thus preventing generated signals to reach supply. It ensures that signal is transmitted to output terminals through C4 coupling capacitor.

## 11.6 CRYSTAL OSCILLATOR

When some crystallized materials are placed between two metal plates and pressurized, crystal starts to vibrate and an electric energy is generated between metal plates. This is called piezo-electric effect. Some of such kind of materials are quartz, tourmaline and rochelle salt. All crystals vibrate at only a specific frequency. This vibration frequency is between 1KHz and 30MHz. Oscillators can be controlled by crystals. In this application, oscillator makes oscillation at a delicate frequency value. Losses of tank circuits are very low when they are made using crystals. Oscillation frequencies of crystals are not affected by heat. In Figure 11. 10, symbol and equivalent circuit of crystal is shown. The value of CS serial capacitor is between 0,05pF and 1pF; the value of CP parallel capacitor is between 5pF and 10pF.

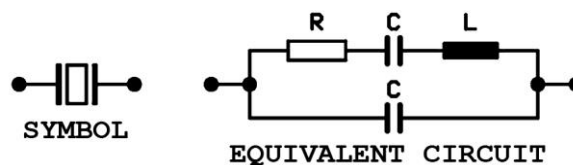

**Figure 11. 10**

Generally, Hartley or colpitts oscillators are controlled by crystal. Crystal colpitts is shown in Figure 11. 11

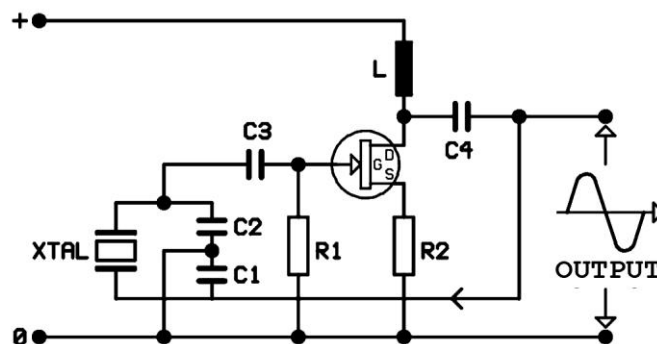

**Figure 11. 11**

Oscillation frequency is equal to frequency (**XTAL**) of crystal. C1 and C2 capacitors should be adaptable to the frequency of crystal. Otherwise, the circuit does not operate as oscillator. Coil of colpitts oscillator is replaced with crystal in the circuit. Magnitude of feedback depends on the values of C1 and C2 capacitor values. Load of FET transistor is the coil with the value of 100mH. Coil presents great opposition to high frequency signals thus preventing generated signals to reach supply. It ensures that signal is transmitted to output terminals through C4 coupling capacitor.

## 11.7 WIEN BRIDGE OSCILLATORS

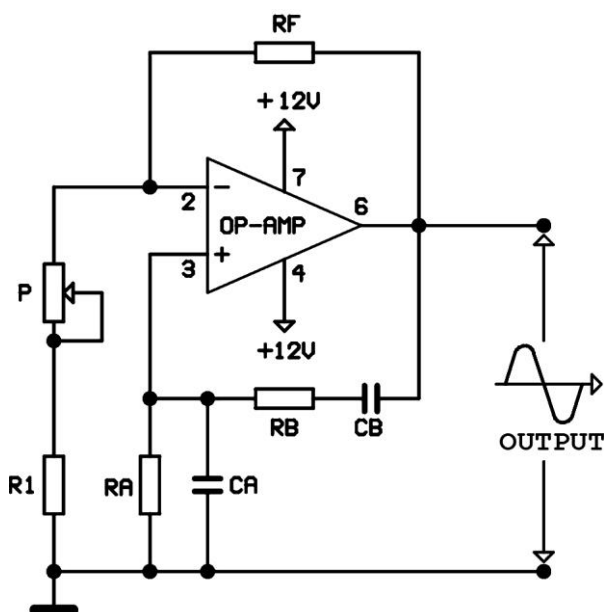

**Figure 11. 12**

As seen in Figure 11. 12, Wien bridge oscillator is made of RC (**resistor and capacitor**) components. The integrated circuit used in circuit is an operational amplifier (**op\_amp**). Operational amplifiers are commonly used components in electronics.

$R_F$  and  $R_1$  resistors are the gain restriction resistors. oscillation frequency of circuit depends on the  $R_A$ - $R_B$  resistors and  $C_A$ - $C_B$  capacitors. Positive feedback is maintained by these components.

Oscillation frequency of circuit ( **$F_o$** ):

$$F_o = \frac{1}{2\pi\sqrt{R_A.R_B.C_A.C_B}}$$

Generally,  $R_A=R_B$  and  $C_A=C_B$  in Wien bridge oscillators. Oscillation frequency is calculated by the following formula:

$$F_o = \frac{1}{2\pi RC}$$

**In Formula:**

**$F_o$** =Oscillation (**resonance**) frequency (**Hz**),

**R** =Resistance (**Ohm**),

**C** =Capacity (**Farat**).

Wien bridge oscillator is used in sound frequency circuits (**20Hz-20KHz**). It is commonly used because frequency and amplitude of output signal is not affected by heat. The only disadvantage is that it needs symmetrical supply.